



## SDH166D SoundFX®

### Fits many HO locomotives

2 Selectable Steam & Diesel Sound Schemes Included

### HO Scale

Mobile Decoder with SoundFX  
Digitrax Easy Connect 9 Pin Harness  
1.0 Amp/2 Amps Peak  
6 FX<sup>3</sup> Functions, 200ma output  
8 Ohm 16 x 26 x 9mm Box Speaker  
330uF Capacitor

## Features:

---

### ■ Digitrax SoundFX® Sound System

Your locomotives will sound in scale like the real thing with SoundFX

Customizable 8 Bit Sound

Works with SoundFX 8 Bit sound files

3 Simultaneous Voices

Downloadable Sound with Digitrax PR3 and SoundLoader 2.0 software

4 Megabit Onboard Sound Memory

1 Watt Sound Output

Cam input-synchronized Steam-chuff option for Steam locos

Scaleable Speed Stabilization(BEMF) optimized for sound operation

■ SoundFX does not require an external rate sensor to vary workload.

■ Factory 8 Ohm 16 x 26 x 9 mm box speaker on 10 Pin Plug design makes installation quick and easy.

■ Smart Power Management-no more booster or programmer shutdowns!

■ Program CVs using any Digitrax Compatible Control system without having to buy any extra equipment.

■ Digitrax Easy Connect 9 Pin Plug for Track, Motor and Function Control.

■ Series 6 Decoder Features.

■ Works with PX112-10 Power Extender.

■ Digitrax FX<sup>3</sup> Functions-Control lights and functions for prototypical lighting effects and on/off control.

■ Configurable FX<sup>3</sup> Pulse Function available on all function outputs.

■ Digitrax LocoMotion® System – Lets your trains run like the real thing!

■ 2 Digit and 4 Digit Addressing.

■ Basic, Advanced & UniVersal Consisting.

■ SuperSonic motor drive for silent operation.

■ Direct mode programming.

■ Decoder Reset CV with or without speed table reset.

■ Transponder Equipped ready for transponding on your Layout.

■ Motor Isolation Protection helps prevent damage to your decoder.

■ DCC Compatible.

■ FCC Part 15, Class B RFI compliant.

■ Digitrax “No Worries” Warranty.

## Parts List

---

1 SDH166D Function Decoder with SoundFX®

1 Instruction Sheet

1 10 Pin Sound Harness - 8 Ω 16 x 26 x 9 mm box speaker and 330uF cap

1 9 Pin Digitrax easy connect Track, Motor, and Function Harness

## Installation Information

---

See the Digitrax Decoder Manual for complete decoder test procedures, installation instructions, programming and technical information. Digitrax manuals and instructions are updated periodically. Please visit [www.digitrax.com](http://www.digitrax.com) for the latest versions, technical updates and additional locomotive-specific installation instructions. **CAUTION: Programming and layout track must not exceed 16V when using this decoder.**

## Installation Instructions

---

### Figure 1: SDH166D Decoder Connections

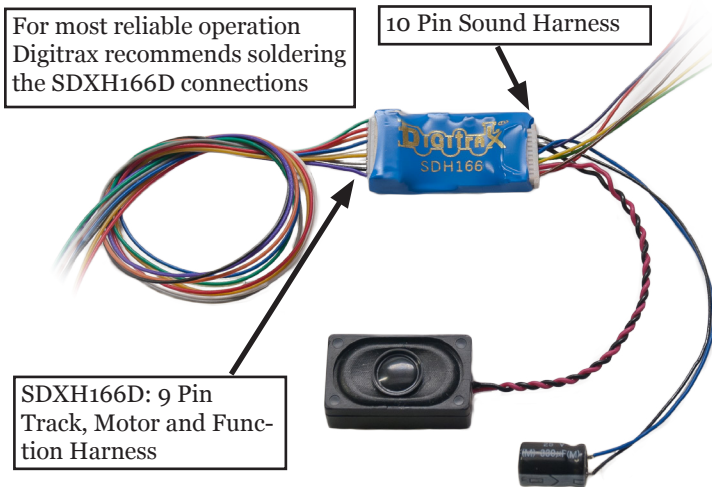

*SDH166D showing 10 Pin Sound Harness with 8 Ohm 16 x 26 x 9mm box speaker and 330uF capacitor*

1. On the 9 Pin Track, Motor and Function Harness solder the Red and Black track leads to the locomotive track power connections. Next solder the Orange and Gray motor leads to the isolated motor connections. Motor connections must be isolated from the track connections. Note that to be able to read back SoundFX CVs either a motor load must be connected to the Orange and Gray leads or a combination of function loads of at least 60mA at 12volts must be connected to the function leads.

2. On the 9 Pin Track and Function harness connect the function leads that are to be used for e.g. lights. Insulate any unused function leads so they cannot short to the locomotive frame or track power.
3. Mount the factory 8 ohm 16 x 26 x 9mm box speaker attached to the 10 Pin Sound Harness in a suitable location (refer to **Figure 2**). Be sure to inspect the speaker diaphragm for magnetic debris or damage, which will affect sound quality. Other speaker(s) may be substituted in combinations as long as the total impedance between Pin 3 and Pin 8 of the 10 Pin Sound Harness is 8 ohms or greater.

Depending on the locomotive model and construction it may be necessary to modify the frame or parts of the internal shell to make room for one or more speakers and enclosures.

**Figure 2: SDH166D: Install example in Athearn SD-70MAC with 9-Pin plug**

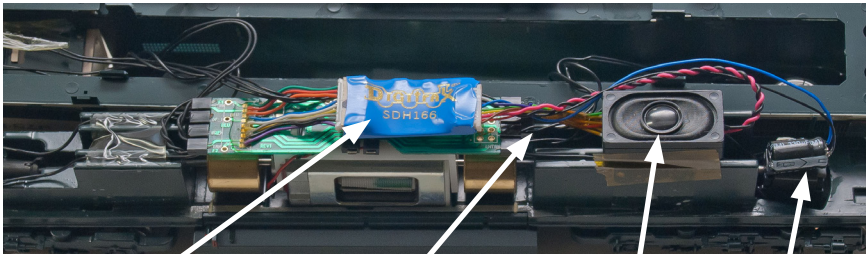

SDH166D decoder on double sided tape on top of light board

Decoder wires - formed to avoid moving parts

Speaker Installed

330uF Energy storage capacitor

4. Mount the 330uF electrolytic energy storage capacitor from the 10 Pin Sound Harness. Be sure not to short the capacitor case or leads to the track leads or locomotive frame or damage to the decoder may result.
5. For Steam units using external synchronization cam capability, connect the White CAM wire of the 10 Pin sound harness to the output connection of your cam, and configure CV133 to a value of 128 to make the steam chuff to be synchronized with the external cam.
6. Inspect the installation before testing the sounds and replacing the shell. In particular be sure that wires are correctly soldered and routed and that the motor and capacitor leads are not shorted to the frame or track.
7. Place the loco on an active DCC track powered by a compatible DCC system and select the factory default address 03 to enable sounds for testing.
8. Be sure F8 (mute) is OFF to allow sound output, and then press F1 (bell) or F2 (whistle/horn) ON to hear the associated sounds.
9. Customize sounds by programming Sound CVs to adjust the desired configurations, as shown in the following tables of SoundFX CVs. Sound schemes other than the factory preloaded default Steam (CV60=0) or Diesel (CV60=1) schemes can be loaded by using a Digitrax PR3 SoundFX Programmer.

## **Speaker Mounting and baffle or enclosures.**

---

The sound performance of any attached speaker(s) is greatly affected by the mounting system and required baffle or rear enclosure. The included 8ohm box speaker is pre-mounted in a baffle for your convenience, however additional baffles or other mounting systems may need to be taken into consideration when installing.

The baffle is used to isolate the speaker diaphragm front sound waves from the “out of phase” rear sound waves. This minimizes sound cancellation, particularly at lower frequencies. For most efficient sound generation, the cubic volume of the baffle should be as large as practically possible, and the baffle walls should be acoustically rigid so not to allow acoustic interference.

Practical baffle materials are plastic, cardboard and even sheet metal. Common items such as cardboard tubes, soda caps, or 35mm film canisters may be modified and trimmed to create reasonable baffles in the available space. Most HO or O scale or similar locomotives have limited internal volume within the shell, so the choice of speaker mounting benefits from some ingenuity to get best sound performance and space. Of course, you can substitute an alternate after market speaker of the maximum size for the locomotive you have.

## **Customizing Your Decoder**

---

Your Digitrax SDH166D SoundFX decoder is ready to run and will operate and generate sound using address 03 with no additional programming. On your Digitrax system, simply select the locomotive’s address and the sound will start. On some DCC systems, it is necessary to select the locomotive address AND send a command to start the sounds. For a more prototypical railroading experience, your decoder can be customized for your specific locomotive by programming some of the Configuration Variables, or CVs, available. Digitrax Sound decoders can be programmed using either a programming track or with the operations mode using the main line. See the Digitrax Decoder Manual or the Digitrax web site for more information.

**CAUTION: Programming track must not exceed 16V when programming this decoder.**

*Digitrax PS14 is the ideal power supply for the PR3.*

**Initial Test and Programming:** This decoder is preprogrammed and tested with a Steam locomotive sound scheme, and is ready to operate on factory default address 03. Before customizing the decoder it is useful to run it on the factory default address 03 to check the installation. The following sections show how to change the locomotive address and customize the decoder.

For more information on general decoder installation and programming techniques and examples visit [www.digitrax.com](http://www.digitrax.com)

## Changing the Decoder Address

---

The first CV most people change is the decoder address. This allows you to independently control each loco with a unique address. Digitrax decoders are shipped with CV01 (AD2), the two digit address, set to 03. Following is a brief description of how to change the decoder address with a Digitrax DT4XX series throttle. See your Starter Set Manual for complete programming instructions.

1. Place the loco on the **programming track not to exceed 16V**. Go into Program Mode on your system. On DT4XX throttle press **PROG**.
2. Choose AD2 for 2 digit addressing or AD4 for 4 digit addressing.
3. Choose the address you want to set up for the decoder.
4. Complete address programming by pressing **ENTER**.

**Note:** CV29 must also be programmed to enable 4 digit addressing, this is done automatically by the DT4XX throttles. See your Digitrax Decoder Manual or the Digitrax Toolbox App for how to set up CV29.

## Using this decoder in other locomotives

---

The factory supplied sound project loaded into the SDH166D is for a Steam (default) or SD38-2 diesel locomotive, selectable with the value in CV60. If you want to install it in a different locomotive, you can simply load a different sound project for that type of locomotive. The cam input is available for Steam installations where you want to synchronize chuffing.

## Digitrax LocoMotion® System

---

Your locomotives look like the real thing, now you can make them run like the real thing, too. Digitrax decoders incorporate torque compensation for smooth as silk operation. You can also program CVs that control momentum, 3 step and 128 step speed tables, switching speed, normal direction of travel, scalable speed stabilization and more to take full advantage of the Digitrax LocoMotion System.

### Momentum-CV03 & CV04

---

Momentum is part of the LocoMotion System. Acceleration is controlled by CV03 and deceleration by CV04. Both come from the factory set to 000. A range of 000 to 031 is available for both accel and decel. Try CV03:003 and CV04:000 as a starting point for experimenting with momentum.

### Speed Tables-How the Loco Responds to the Throttle

---

With Digitrax LocoMotion, there are two types of speed tables: 3 Step Tables and High Resolution 28 Step Tables. Please see your Decoder Manual for a discussion of the 28 Step Tables. The 3 Step Tables are set up by programming 3 CVs: Start Voltage (CV02), Mid point Voltage (CV06) and Max Voltage (CV05). These values are set at 000 at the factory. All have a range of values from 000 to 255. We recommend the following CV values as a starting point for experimenting with speed tables.

Loco Type	V Start CV02	V Mid CV06	V Max CV05
<b>Switcher</b> Concentrated low speed. Limited top speed	002	038	064
<b>Road Switcher</b> Prototypical top speed w/evenly distributed curve from 0 to top speed	002	048	098
<b>Mainline Loco</b> Quick increase to cruising speed then levels off to prototypical top speed.	002	128	154

### Decoder Reset CV08

---

Decoder reset lets you reset all CV values to the initial factory settings. To reset all CV values, program CV08 to a value of 008. You also have the option of resetting all values except the 28 speed step tables. To do this, program CV08 to a value of 009.

## **Other LocoMotion® Features: Switching Speed, Normal Direction of Travel & Scalable Speed Stabilization (Back EMF) Features**

---

**Switching speed** is controlled by CV54. The factory setting is 000 for OFF. To turn on the switching speed feature, program CV54 to a value of 001. When this feature is on, use F6 to activate and deactivate switching speed. With the feature on the throttle's target speed is effectively reduced by about 50% and the effects of accel and decel programmed into the decoder are reduced by 1/4. This is useful for yard switching operations.

**Normal Direction of Travel** is controlled by CV29. See your decoder manual or the Digitrax Toolbox App for additional information on the settings for CV29.

## **Digitrax SoundFX® System**

---

Digitrax SoundFX lets you make your locos sound in scale like the real thing! The SoundFX sound CVs in the range of CV140 to CV256 let you customize your decoder without having to reprogram or change the installed sound scheme. Standard decoder CVs in the range of CV01 to CV120 operate the same as for a non-SoundFX<sup>3</sup> Digitrax decoders (they control motor and light functions etc.) CV58 is used as Master Volume, and CV60 is used to select an alternate scheme, if provided in the sound project. Sound CV155 is provided to select Diesel engine “notching” modes. The default of CV155=00 provides “automatic notching” that changes the diesel RPM settings at 8 distinct throttle speeds that are controlled by Sound CV132. Sound CV155=01 selects “semi-automatic notching” mode that allows F6 ON to increase the notch from the current throttle setting and F7 ON to decrease back towards the lowest current throttle notch setting. Sound CV155=02 selects “manual notching” mode that allows F6 ON to increase the notch setting and F7 ON to decrease the notch setting irrespective of the throttle setting, which controls just the motor speed. The decoder's sound scheme can be reloaded using a Digitrax PR3 programmers and a sound project file from the Digitrax Sound Depot on our web site. Typical sound downloads take between 50 and 100 seconds depending on the project complexity and file size. The following tables show the CVs used in this decoder version and how it is set up at the factory to operate various sounds using your throttle

CV#	Used For	Range	Default Value
01	2 Digit Address		03
11	Sound Time Out, 06 = Sound ends when loco address is de-selected, 00=Sound stays on after loco is de-selected		06
29	Configuration Register - Advanced or Standard speed steps, 2 or 4 digit addressing, Analog Mode, Normal direction of travel, speed tables		06
49	Forward Light (FOF) - Headlight		00
50	Reverse Light (FOR) - Reverse Light		00
51	Function 1		00
52	Function 2		00
58	Master Volume (F8 used for Mute) 1=min 00=max	00-15	09
60	Scheme 0=Steam 1=GP38 Diesel	00-01	00
132	Notch Rate	00-255	127
133	Steam Chuff/CAM config, 128=>EXT cam, 1-127=>DRIVER dia in inches	01-128	63
134	Steam Gear Ration Trim, 32 = 100% Ratio	00-255	32
135	Mute Volume	00-64	00
140	Prime Mover / Chuff Volume	00-64	60
141	Bell Volume	00-64	25
142	Horn/Whistle Volume	00-64	60
143	Time-Scattered Air Effects Volume	00-64	30
145	Misc Vols	00-64	40
146	Bell Ring Rate (1=24 milliseconds)	01-100	07
147	Air Drier Rate (1-about 2 seconds)	01-64	02
148	Compressor Run Rate	00-255	30
149	Air Compress On Time	00-255	20
150	Horn/Whistle Setup (Default=0, Playable Horn=1, Alternate Horn=2 +128 for playable volume.)	00-07 or 128-135	00
151	Auto Coupler Sequence Threshold Value-Peak speed to allow auto coupler/brake when direction change occurs and F3 is ON	00-64	48
152	Project Author ID, Digitrax=221		221
153	Project ID, Steam/SD38_2		02
154	Steam Blow down / Safety Volume	0-64	60
155	Notching/Slip Mode: 00=Automatic,		00



Function	Used For	Notes
F0	Lights	
F1	Bell	
F2	Horn/Whistle	CV150 sets mode
F3	Coupler crash	Auto coupler/brake set by CV151 max speed
F4	Air feature disable	F4 off enables pop-off, drier and starts compressor/airpump
F5	Diesel = Dynamic brake Fans Steam = Water Pump turbine	
F6	Diesel = Notch Up Steam = Blowdown	Notch UP if CV155=01 or 02
F7	Crossing Gate Airhorn or; Diesel = Notch DOWN Steam = Wheelslip	Notch DOWN, if CV155 = 01 or 02 (Crossing Gate active if in Diesel mode and CV155=0)
F8	Mute Control	F8 ON is mute
F9	Brake squeal	
F10	Crossing Gate Airhorn Sequence	
F11	Steam = Greaser	
F12	Steam = Safety Blowoff	

## SoundFX DC Operation Mode

Digitrax SoundFX decoders will operate on smooth DC power. The sound will not start until approximately 7 volts is applied to the track and there will be no “start up sound.”

## SDH166D Troubleshooting

---

### **If the sound does not start in the decoder**

1. Make sure you have selected the locomotive address on a throttle. The sound will not run unless the locomotive is addressed in the system.
2. Check your installation to make sure the decoder is installed properly.

### **If the sound output sounds distorted**

1. Check the speaker cone for magnetic debris that may have collected there. Debris on the speaker will cause a loss of sound quality and must be removed.
2. Be sure that the CV58 volume is not set at a level that is too high for the speaker being used.

**If the sound in your decoder shuts down after you stop it and you are not using a Digitrax system for control.** On some DCC systems decoders are not addressed by DCC packets after the locomotive is set to 0 speed. In this case after the CV11 timeout elapses (6 second default), sound will “shutdown.”. To defeat this feature, set CV11=00 to remove the timeout and shutdown. *To make sounds, the decoder must have a command addressed to it at least once.*

**If you have trouble reading back CVs on the programming track,** this may be due to insufficient current draw. Of course you can always just re-program the CV value into a CV to get the desired results, even if reading CVs does not work. OPS mode is recommended for writing to (programming) all CVs except CV01, CV17 & CV18 (2 digit and 4 digit addresses). If a second DCC decoder is present that is not SoundFX compatible then correct read back of CV data is not possible, since the NMRA CV read back was not designed for multiple decoder read back.

### **The SDH166D plays a Diesel scheme, but I want the Steam scheme.**

If the factory scheme has not been erased, program CV60 to a value of 0 to reselect the Steam scheme. Alternatively set CV60 to 01 to change to the SD38-2 sound scheme.

**I have loaded a new scheme but the CVs and Functions are not what I expected.** Load the sound project you programmed and then select the view>project description” menu and then read the text file on the screen that defines how that project in particular uses CVs and functions for sound generation and configuration.

## Warranty & Repair

---

Digitrax gives a one year “*No Worries*” *Warranty* against manufacturing defects and accidental customer damage on all Digitrax command stations, boosters, throttles, decoders, power supplies and layout control devices.

### **That’s it! A simple, straightforward warranty with no tricky language!**

Visit [www.digitrax.com](http://www.digitrax.com) for complete warranty details and instructions for returning items for repair.

**Please return warranty items directly to Digitrax - DO NOT** return items to place of purchase.

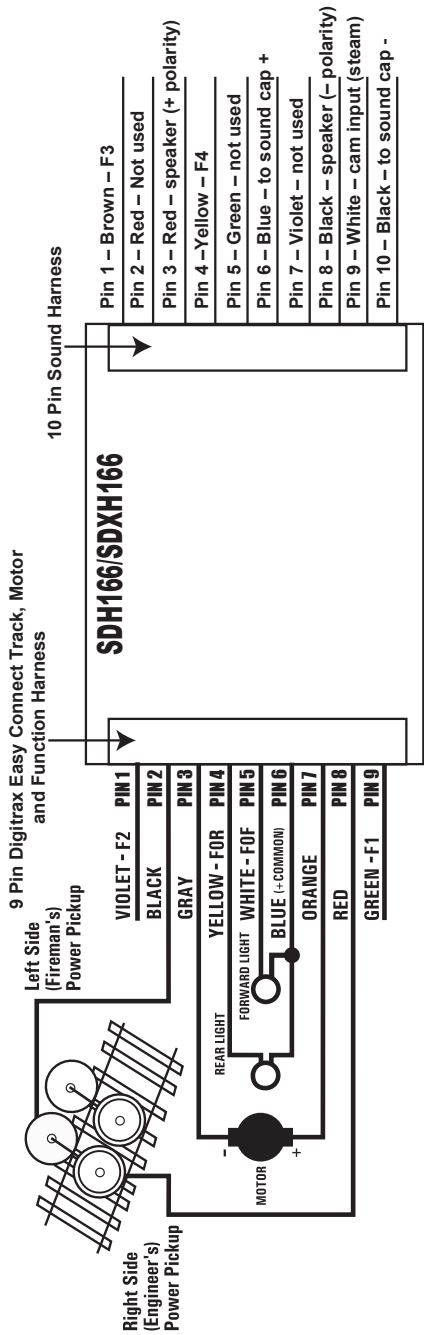

Figure 3: SDH166D: connection diagram



# SDH166D

Wired Sound + Motor + Function Decoder for HO scale locomotives

## Go Beyond DCC With Digitrax® Complete Train Control

### Main Station

Starter Sets  
LocoNet®  
Power Supplies



Your Digitrax LocoNet® Starter Set is just the beginning of an exciting trip! Pick the one that's right for you!



LocoNet®  
The Digitrax  
Difference

### Locomotive Shops

Mobile Decoders  
Function Decoders  
SoundFX™ Decoders

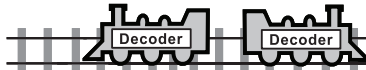

### More Fun For Everyone

Add More Boosters, Advanced & Simple Throttles, Power Supplies, Universal Panels, IR and/or Radio for more trains and operators.

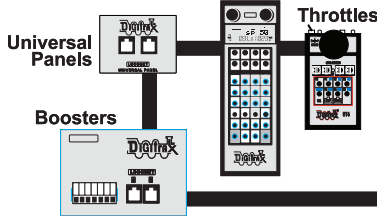

### Maintenance Of Way

Make your layout more fun & simpler to operate!

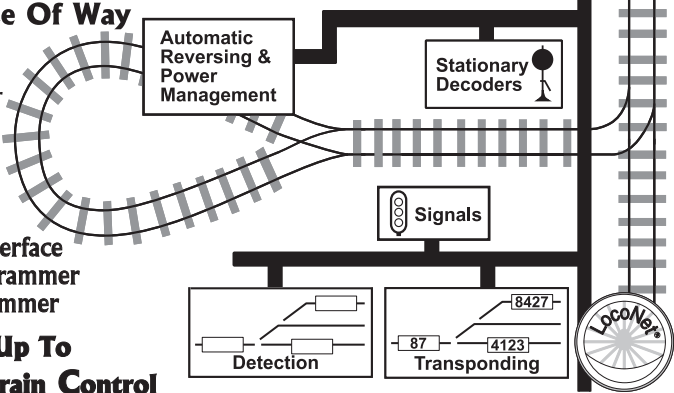

### Computer Controls

Computer Interface  
Decoder Programmer  
Sound Programmer

### It All Adds Up To Complete Train Control



2443 Transmitter Road  
Panama City, FL 32404

[www.digitrax.com](http://www.digitrax.com)

Made in the USA

Contact: [www.digitrax.com/contact](http://www.digitrax.com/contact)

Support: [techsupport@digitrax.com](mailto:techsupport@digitrax.com)

Repair: [repair@digitrax.com](mailto:repair@digitrax.com)

SDH166D



6 52667 20022 6

