



BD4N

DCC 4 Block Occupancy Detector

Features:

- Low-cost, High-sensitivity DCC block-occupancy detection.
- Adjustable resistance/current detection section (DS) trip threshold.
- 8A capacity, suitable for all scales and track wiring configurations.
- Noise resistant and compatible with BDL168 sections.
- On-board status leds for stand-alone occupancy and track power indication, expandable for optional LT5 or fascia mounted occupancy indicator leds.
- Plug and Play connections to simplify setup. Can cascade Booster wires.
- Isolated Occupancy output signal lines can drive most common signal system or control interfaces.
- Compatible with DS64 and SE8 modules for signaling, control and reporting occupancy onto LocoNet.

Parts List

- | | |
|--------------------------------|---------------------|
| 1 BD4N Quad Occupancy Detector | 1 4-pin Power plug |
| 1 4-pin DS plug | 1 Instruction Sheet |

BD4N Installation

The BD4N is simple to install, plug in and begin using on your layout.

1. It is recommended the BD4N be placed close to the DS's (detection sections) to minimize the lighter gauge feeder resistances.
2. Connect the RailA and RailB bus from the Booster to the Power in connector, matching adjacent power districts rail connection polarity. After installation the red PWR led will light when the Booster track power is ON. Both the RailA and RailB booster connections also are available on the Power connector to daisy-chain to additional units, up to 8amps total current draw.
3. Connect the four DS connections from the DS plug to the track sections to be detected. The RailA connection is common to all DS sections as the "other rail" for detection, refer to the drawing overleaf.
4. When the PWR led is ON the matching red DS leds will light when the minimum current draw is seen in that DS. If the OCC_TRIP pot is turned fully CCW, the unit will need higher DS current to detect occupancy.
5. You can use the OCC_LEDS 10-pin header and ribbon cable to optionally wire directly to remote leds on e.g. the fascia. If these leds are plugged in they will automatically turn off the onboard indicator leds.
6. The 10-pin OCC_OUT header can use a ribbon cable to optionally expand to a separate signaling or reporting device such as a DS54/64 or SE8 etc. The four detection outputs in this cable are fully isolated, so can drive any type of device safely. Be sure to wire the pin1/brown Common+ lead to a voltage source to allow these occupancy signals to operate as shown in the figure overleaf.

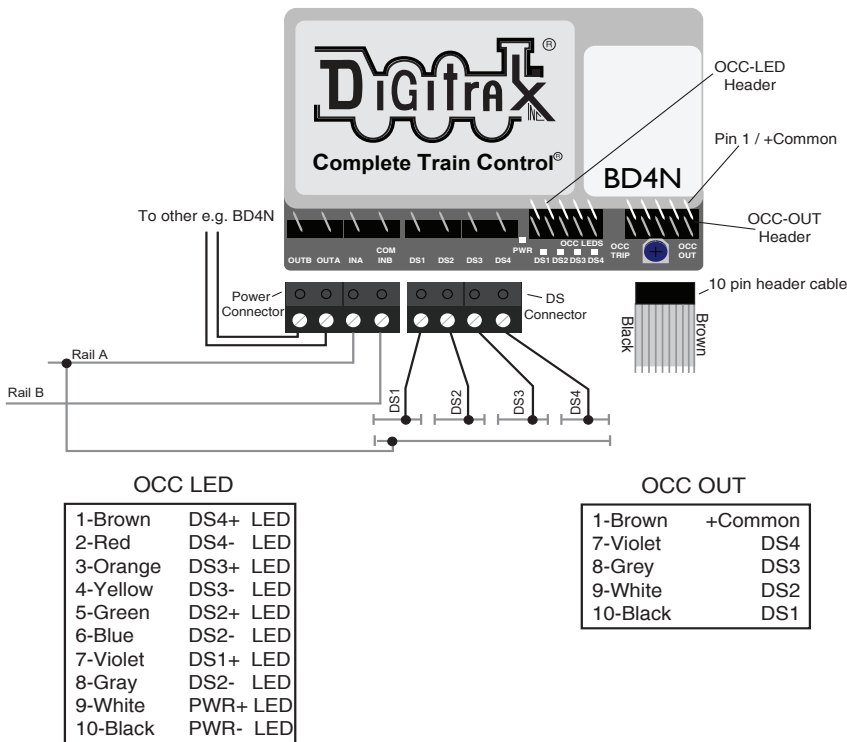

Warranty & Repair

Digitrax gives a one year “No Worries” Warranty against manufacturing defects and accidental customer damage on all Digitrax command stations, boosters, throttles, decoders, power supplies and layout control devices.

That’s it! A simple, straightforward warranty with no tricky language!

Visit www.digitrax.com for complete warranty details and instructions for returning items for repair.

Please return warranty items directly to Digitrax - DO NOT return items to place of purchase.

Digitrax, Inc. is not responsible for unintentional errors or omissions in this document.



Made in the USA

2443 Transmitter Road
Panama City, FL 32404
www.digitrax.com

Need Support?
helpdesk.digitrax.com

BD4N



307-BD4N-0000