



Complete Train Control
Run Your Trains, Not Your Track!



SFX006 Soundbug™ Decoder Sound Module for HO, N, O Locomotives and Rolling Stock

SFX006: Plug N' Play SoundFX®

With 8 Ohm 16 x 26 x 9mm Box Speaker &
330uF Capacitor Preloaded with 8 selectable
Steam and Diesel Sound Schemes

Features:

- **Plug N' Play sound module for Digitrax DH165 series decoders**
- **Use custom sounds to add sound to rolling stock!**
- **Use custom sounds for stationary and under-layout sound**
- **Digitrax SoundFX® Sound System**
 - Your locomotives will sound in scale like the real thing with SoundFX
 - Customizable 16, 12 or 8 Bit Sound
 - Works with SoundFX 8 and 16 Bit sound projects
 - 4 Simultaneous voices
 - Downloadable Sound with Digitrax PR3 and SoundLoader 2.0 software
 - 16 Megabit On board Sound Memory
 - 1 Watt Sound Output
 - Cam input-synchronized steam-chuff option for steam locos
 - Scaleable Speed Stabilization(BEMF) optimized for sound operation
- Smart Power Management-no more booster or programmer shutdowns!
- Program CVs using any Digitrax Compatible Control system without having to buy any extra equipment.
- Direct mode programming.
- DCC Compatible.
- Runs on up to 16V track voltage
- Download sounds using Digitrax PR3 sound programmer
- FCC Part 15, Class B RFI compliant.
- Digitrax "No Worries" Warranty.

Parts List

- 1 SFX006 Decoder with SoundFX®
- 1 Instruction Sheet
- 1 2/56 x 1/4" mounting screws
- 1 Attached 8 Ohm 16 x 26 x 9mm Box Speaker and 330 uF capacitor

Installation Information

See the Digitrax Decoder Manual for complete decoder test procedures, installation instructions, programming and technical information. Digitrax manuals and instructions are updated periodically. Please visit www.digitrax.com for the latest versions, technical updates and additional locomotive-specific installation instructions. **CAUTION: Programming and layout track must not exceed 16V when using this decoder.**

Installation Instructions

Figure 1: SFX006 Decoder

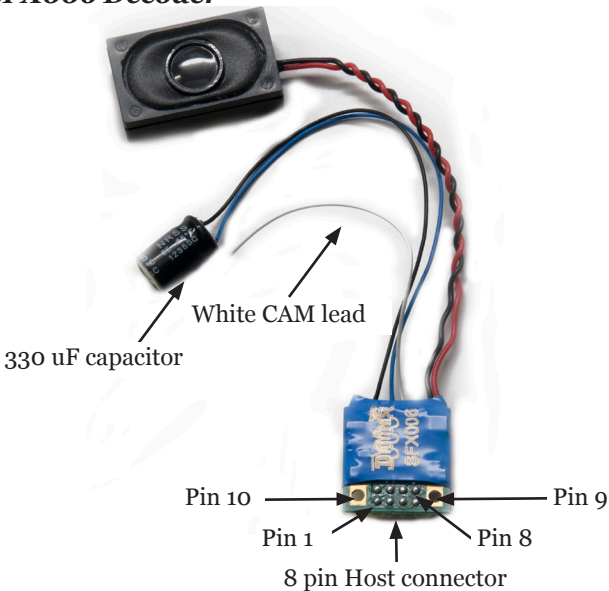

For Installation with DH165 series decoders:

1. Identify the correct orientation and mounting side and of the DH165 series decoder to plug this sound module into. There is text saying “SFX here” etc,. The SFX006 must only be mounted from the correct side and orientation, for each of the DH165 host decoders (see pg13).
2. With correct orientation noted from step 1, align the dual row of SFX006 connector pins to the matching holes in the DH165 host PCB. Apply gentle and firm pressure behind the SFX006 connector to engage the pins until the black plastic connector base almost touches the DH165 host PCB. (The first

pin insertion may take slightly more force to engage).

3. Screw in the two 2/56 screws from the DH165 host PCB down through the SFX006 to ensure the module is retained and parallel to the DH165 host.
4. Mount the attached 8 Ohm 16 x 26 x 9mm Box Speaker in an appropriate sound enclosure. Be sure to inspect the speaker diaphragm for magnetic debris or damage, which will affect sound quality. Other speakers may be substituted in combinations as long as the total impedance on the red/black wires is 8 ohms or greater.
5. Mount the 330uF/25V electrolytic energy-storage capacitor. It is often easiest to use double-sided tape to locate and secure this capacitor. Be sure not to short the capacitor case or leads to the track leads or locomotive frame, or damage to the decoder may result.
6. For Steam units with a synchronization cam capability, connect the White CAM lead to the cam output connection, and program CV133 to 128 for external CAM operation.
7. Inspect the installation before testing the sounds and replacing the shell. Take extra care to inspect that the SFX/SoundBug is clear of any moving parts such as e.g. flywheels in many of the possible locomotive installations.

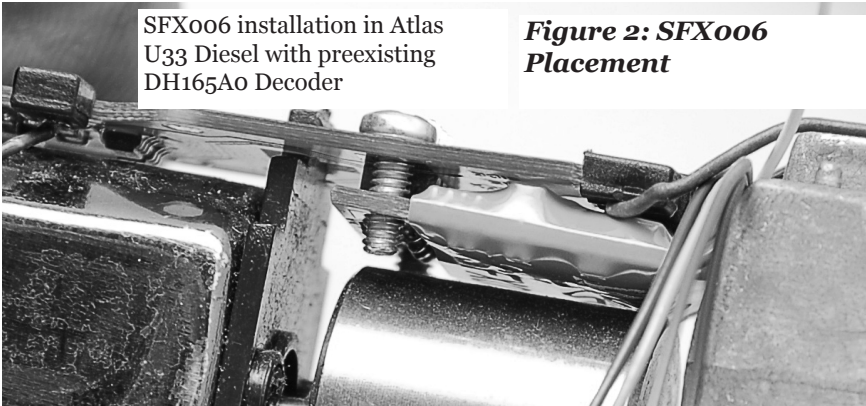

SFX006 installation in Atlas U33 Diesel with preexisting DH165AO Decoder

Figure 2: SFX006 Placement

In most older units tested, using the DH165AO and SFX006 combination, there is typically 1 to 2mm of flywheel clearance, if the Soundbug is correctly mounted flush and parallel to the host DH165 decoder. Space up or shim the DH165 series decoder to ensure an adequate separation with no binding.

8. Connect DCC track power from a compatible DCC system and select the factory default address 03 to enable SFX sounds for testing
9. Be sure F8 is OFF, and then press F1(bell) or F2 (whistle/horn) ON to hear these associated sounds.
10. Customize sounds by programming Sound CVs to adjust the desired configurations, as shown in the following tables of SoundFX CVs. Sound schemes other than the 8 factory preloaded can be loaded by using a Digitrax PR3 SoundFX Programmer.

For standalone operation without a DH165 series host decoder:

The SFX006 can be used in a stand alone configuration either track side or to add sound to rolling stock. In these situations just connect pins 9 and 10 to the track or track pickups and address the device normally. Be careful to not short or connect to any other of the 8 pin connector pins when installing using this method.

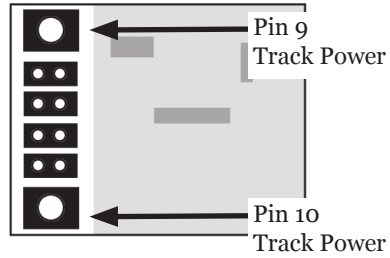

Using the SFX006 with other DCC decoders.

The sound project loaded into this decoder may be operated independently of any other DCC motor or function decoder. If another non-Sound FX compatible DCC decoder is connected to the track leads then CV readback of SFX006 Sound CV's and PR3 SoundTest modes may not be possible. Note that it is always possible to Write CV values using Operations mode or a Service Mode programming track, even if CV Read is inoperative. If the connected function loads are insufficient for CV readback with a PR3 or an incompatible DCC decoder is also connected, it is still possible to download a complete sound project by using the large green “program project” icon. in the SoundLoader program.

Speaker Mounting and baffle or enclosures.

The sound performance of any attached speaker(s) is greatly affected by the mounting system and required baffle or rear enclosure. The included 8ohm box speaker is pre-mounted in a baffle for your convenience, however additional baffles or other mounting systems may need to be taken into consideration when installing or if you use alternate speakers.

The baffle is used to isolate the speaker diaphragm front sound waves from the “out of phase” rear sound waves. This minimizes sound cancellation, particularly at lower frequencies. For most efficient sound generation, the cubic volume of the baffle should be as large as practically possible, and the baffle walls should be acoustically rigid so not to allow acoustic interference.

Practical baffle materials are plastic, cardboard and even sheet metal. Common items such as cardboard tubes, soda caps, or 35mm film canisters may be modified and trimmed to create reasonable baffles in the available space. Most HO or O scale or similar locomotives have limited internal volume within the shell, so the choice of speaker mounting benefits from some ingenuity to get best sound performance and space. Of course, you can substitute an alternate after market speaker of the maximum size for the locomotive you have.

Customizing Your Decoder

Your Digitrax SFX006 Soundbug™ is ready to run and will operate and generate sound using address 03 with no additional programming. On your Digitrax system, simply select the locomotive's address and the sound will start. On some DCC systems, it is necessary to select the locomotive address AND send a command to start the sounds.

When used in conjunction with a separate DCC motor decoder in a single locomotive it is most practical to program both decoders to the same address and operating modes.

For a more prototypical railroading experience, your decoder can be customized for your specific locomotive by programming some of the Configuration Variables, or CVs, available. Digitrax Sound decoders can be programmed using either the direct method on a programming track or with the operations mode using the main line. See the Digitrax Decoder Manual or the Digitrax web site for more information.

Initial Test and Programming: This decoder is preprogrammed and tested with a Steam locomotive sound scheme, and is ready to operate on factory default address 03. Before customizing the decoder it is useful to run it on the factory default address 03 to check the installation.

The following sections show how to change the locomotive address and customize the decoder.

For more information on general decoder installation and programming techniques and examples visit www.digitrax.com

Changing the Decoder Address

The first CV most people change is the decoder address. This allows you to independently control each loco with a unique address. Digitrax decoders are shipped with CV01 (AD2), the two digit address, set to 03. Following is a brief description of how to change the decoder address with a Digitrax DT4XX series throttle. See your Starter Set Manual for complete programming instructions.

1. Place the loco on the **programming track not to exceed 16V**. Go into Program Mode on your system and make sure the throttle is set for the programming mode (Pg, Pd, Po). On DT4XX throttle press **PROG**.
2. Choose AD2 for 2 digit addressing or AD4 for 4 digit addressing.
3. Choose the address you want to set up for the decoder.
4. Complete address programming by pressing **ENTER**.

Note: CV29 must also be programmed to enable 4 digit addressing, this is done automatically by the DT4XX throttles. See your Digitrax Decoder Manual or the Digitrax Toolbox App for how to set up CV29.

Using this decoder in other locomotives

The factory supplied sound project loaded into the SFX006 is for a GP38 diesel locomotive, other preloaded projects are selectable with the value in CV60. If you want to install it in a different locomotive, you can simply load a different sound project for that type of locomotive. The cam input is available for Steam installations where you want to synchronize chuffing.

Digitrax LocoMotion® System

The SFX006 does not have a motor drive capability but uses the DCC CV's associated with motor drive to synchronize the generation of prime move sounds.

Momentum-CV03 & CV04

Momentum is part of the LocoMotion System. Acceleration is controlled by CV03 and deceleration by CV04. Both come from the factory set to 000. A range of 000 to 031 is available for both accel and decel. Try CV03:003 and CV04:000 as a starting point for experimenting with momentum.

Speed Tables-How the Loco Responds to the Throttle

With Digitrax LocoMotion, there are two types of speed tables: 3 Step Tables and High Resolution 28 Step Tables. Please see your Decoder Manual for a discussion of the 28 Step Tables. The 3 Step Tables are set up by programming 3 CVs: Start Voltage (CV02), Mid point Voltage (CV06) and Max Voltage (CV05). These values are set at 000 at the factory. All have a range of values from 000 to 255. We recommend the following CV values as a starting point for experimenting with speed tables.

Loco Type	V Start CV02	V Mid CV06	V Max CV05
Switcher Concentrated low speed. Limited top speed	002	038	064
Road Switcher Prototypical top speed w/evenly distributed curve from 0 to top speed	002	048	098
Mainline Loco Quick increase to cruising speed then levels off to prototypical top speed.	002	128	154

Other LocoMotion® Features: Switching Speed, Normal Direction of Travel

Switching speed is controlled by CV54. The factory setting is 000 for OFF. To turn on the switching speed feature, program CV54 to a value of 001. When this feature is on, use F6 to activate and deactivate switching speed. With the feature on the throttle's target speed is effectively reduced by about 50% and the effects of accel and decel programmed into the decoder are reduced by 1/4. This is useful for yard switching operations.

Normal Direction of Travel is controlled by CV29. See your decoder manual for additional information on the settings for CV29.

Decoder Reset CVo8

Decoder reset lets you reset all CV values to the initial factory settings. To reset all CV values, program CVo8 to a value of 008. You also have the option of resetting all values except the 28 speed step tables. To do this, program CVo8 to a value of 009.

Digitrax SoundFX® System

Digitrax SoundFX lets you make your locos sound in scale like the real thing! The SoundFX sound CVs in the range of CV140 to CV256 let you customize your decoder without having to reprogram or change the installed sound scheme.

Diesel Notching CV132 and 155

Sound CV155 is provided to select Diesel engine “notching” modes. The default of CV155= 00 provides “automatic notching” that changes the diesel RPM settings at 8 distinct throttle speeds that are controlled by Sound CV132. Sound CV155=01 selects “semi-automatic notching” mode that allows F6 ON to increase the notch from the current throttle setting and F7 ON to decrease back towards the lowest current throttle notch setting. Sound CV155=02 selects “manual notching” mode that allows F6 ON to increase the notch setting and F7 ON to decrease the notch setting irrespective of the throttle setting, which controls just the motor speed.

Steam Chuff / Cam Configuration and Gear Rotation Trim CV133 and 134

CV133 controls the Steam Chuff / Cam configuration in the decoder it allows you to get the value of the CV equal to the diameter of the driver in inches from 1-27 or to set the CV to 128 to enable the external cam lead. CV134 controls the gear rotation trim where a value of 32 equals a 100% ratio.

Bell and Air Effect Rates CV146-149

CV146 controls the bell rate or time between ring of the bell, it has a range from 1-100 with each increment adding 24ms of delay. CV147 controls the drier rate, it has a range from 1-64 with each increment adding about 2 seconds. CV148 controls the Compressor/ Air pump start rate and CV149 controls how long the Compressor/ Air Pump runs.

Auto Coupler Sequence Threshold Value CV151

CV151 controls the threshold at which coupler and brake sounds are automatically played when locomotive direction is changed and function 3 is enabled. CV151 has a range of 0-60.

Changing the Sound Scheme on your SFX006 CV60, 150, 157

The SFX006 comes preloaded with 8 different sound schemes, 6 diesel and 2 Steam. These schemes can be selected using CV60. Each diesel scheme can be configured with one of 8 different horns using CV150 and one of 4 different bells using CV157. Each Steam scheme can be configured with one of 3 whistles using CV150 and one of 4 bells using CV157. To enable playable volume for your selected horn or whistle add 128 to the selected value (ex. Playable volume on horn 2 is enabled with a value of 130, 02+128=130)

Loading Other Sound Schemes in your SFX006

The decoder's sound scheme can be changed using a Digitrax PR3 programmer and your computer with the SoundLoader 2.0 software. Both the software and a number of alternate sound project files are available from the Digitrax Sound Depot web site. It takes only a few minutes to download the new sound to your decoder. The following tables show the CVs used in this decoder version and how it is set up at the factory to operate various sounds using your throttle. **(Table on next page.)**

CV60 set to	Sound Scheme	CV150 set to	CV157 set to
0	GP38 Diesel	0= default 1-7= alt horns 128-135 = Playable horns	0=default 1-3 = alt bells
1	GE Evolution Diesel	0= default 1-7= alt horns 128-135 = Playable horns	0=default 1-3 = alt bells
2	SD70 Diesel	0= default 1-7= alt horns 128-135 = Playable horns	0=default 1-3 = alt bells
3	GP10 Diesel	0= default 1-7= alt horns 128-135 = Playable horns	0=default 1-3 = alt bells
4	RS1 Diesel	0= default 1-7= alt horns 128-135 = Playable horns	0=default 1-3 = alt bells
5	C420 Diesel	0= default 1-7= alt horns 128-135 = Playable horns	0=default 1-3 = alt bells
6	Steam type 1 (based on 3985)	0= default 1-2= alt whistles 128-130 = Playable whistles	0=default 1-3 = alt bells
7	Steam type 2 (based on K27)	0= default 1-2= alt whistles 128-130 = Playable whistles	0=default 1-3 = alt bells

CV#	Used For	Range	Default Value
01	2 Digit Address		03
11	Sound Time Out, 06 = Sound ends when loco address is de-selected, 00=Sound stays on after loco is de-selected		06
29	Configuration Register - Advanced or Standard speed steps, 2 or 4 digit addressing, Analog Mode, Normal direction of travel, speed tables		06
49	Forward Light (FOF) - Headlight		00
50	Reverse Light (FOR) - Reverse Light		00
51	Function 1		00
52	Function 2		00
58	Master Volume (F8 used for Mute) 1=min 00=max	00-15	09
60	Sound Scheme Select	00-07	00
132	Notch Rate	00-255	127
133	Steam Chuff/CAM config, 128=>EXT cam, 1-127=>DRIVER dia in inches	01-128	63
134	Steam Gear Ration Trim, 32 = 100% Ratio	00-255	32
135	Mute Volume	00-64	00
140	Prime Mover / Chuff Volume	00-64	60
141	Bell Volume	00-64	25
142	Horn/Whistle Volume	00-64	60
143	Time-Scattered Air Effects Volume	00-64	30
145	Misc Vols	00-64	40
146	Bell Ring Rate (1=24 milliseconds)	01-100	07
147	Air Drier Rate (1-about 2 seconds)	01-64	02
148	Compressor Run Rate	00-255	30
149	Air Compress On Time	00-255	20
150	Horn/Whistle Setup (Default=0, Playable Horn=1, Alternate Horn=2 +128 for playable volume.)	00-07 or 128- 135	00
151	Auto Coupler Sequence Threshold Value-Peak speed to allow auto coupler/brake when direction change occurs and F3 is ON	00-64	48
152	Project Author ID, Digitrax=221		221
153	Project ID		168
154	Steam Blow down / Safety Volume	0-64	60
155	Notching/Slip Mode: 00=Automatic,		00
157	Bell Selector	00-03	00

Function	Used For	Notes
F0	Lights	
F1	Bell	
F2	Horn/Whistle	CV150 sets mode
F3	Coupler crash	Auto coupler/brake set by CV151 max speed
F4	Air feature disable	F4 off enables pop-off, drier and starts compressor/airpump
F5	Diesel = Dynamic brake Fans Steam = Water Pump turbine	
F6	Diesel = Notch Up Steam = Blowdown	Notch UP if CV155=01 or 02
F7	Crossing Gate Airhorn or; Diesel = Notch DOWN Steam = Wheelslip	Notch DOWN, if CV155 = 01 or 02 (Crossing Gate active if in Diesel mode and CV155=0)
F8	Mute Control	F8 ON is mute
F9	Brake squeal	
F10	Crossing Gate Airhorn Sequence	
F11	Steam = Greaser	
F12	Steam = Safety Blowoff	

SoundFX DC Operation Mode

Digitrax SoundFX decoders will operate on smooth DC power. The sound will not start until approximately 7 volts is applied to the track and there will be no “start up sound.”

SFX006 Troubleshooting

If the sound does not start in the decoder

1. Make sure you have selected the locomotive on a throttle. The sound will not run unless the locomotive is addressed in the system.
2. Check your installation to make sure the decoders are installed properly.

If the sound output sounds distorted

1. Check the speaker cone for magnetic debris that may have collected there. Debris on the speaker will cause a loss of sound quality and must be removed.
2. Be sure that the CV58 volume is not set at a level that is too high for the speaker. For impedances below 32ohms (e.g. 8 to 30 ohms) set the volume setting lower to ensure the 1 watt output rating is not exceeded.

If the sound in your decoder shuts down after you stop it and you are not using a Digitrax system for control. On some DCC systems decoders are not addressed by DCC packets after the locomotive is set to 0 speed. In this case after the CV11 timeout elapses (6 second default), sound will “shutdown.” To defeat this feature, set CV11=00 to remove the timeout and shutdown. To make sounds, the decoder must have a command addressed to it at least once.

If you have trouble reading back CV’s on the programming track, this may be due to insufficient current draw by the SFX006 for the programmer you are using. Of course you can always just re-program the CV value into a CV to get the desired results, even though reading CV’s does not work. OPs mode is recommended for programming all CVs except CV01, CV17 & CV18 (2 digit and 4 digit addresses). If a second DCC decoder is present that is not Sound FX compatible, then correct readback of CV data is not possible, since the NMRA CV readback method was not originally designed for multiple decoder readback.

I have loaded a new scheme but the CV’s and Functions are not what I expected. Load the sound project you programmed and then select the “view>project description” menu and then read the text file on the screen that defines how that project in particular uses CV’s and Functions for sound generation and configuration.

I cannot run the “SoundTest” feature of the SoundLoader program used in conjunction with a PR3 Programmer. If the Soundbug is combined with a DCC decoder that is not fully SFX compatible, then it may not be possible for the SoundTest feature to activate properly. Of course, it is still possible to hear and exercise the sound scheme by placing the programmed units on a regular DCC track, and operating the functions, etc. Also, it is possible to program the Soundbug with new sound projects using the PR3, and non-SFX compatible decoders should have the Analog Mode conversion capability in CV29 turned OFF.

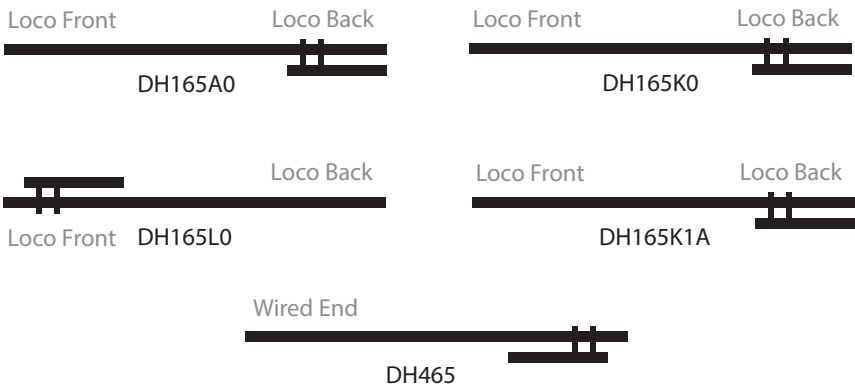

Warranty & Repair

Digitrax gives a one year “*No Worries*” *Warranty* against manufacturing defects and accidental customer damage on all Digitrax command stations, boosters, throttles, decoders, power supplies and layout control devices.

That’s it! A simple, straightforward warranty with no tricky language!

Visit www.digitrax.com for complete warranty details and instructions for returning items for repair.

Please return warranty items directly to Digitrax - DO NOT return items to place of purchase.

This page intentionally left blank

This page intentionally left blank



SFX006
Plug 'N Play SoundFX Decoder

Go Beyond DCC With **Digitrax** Complete Train Control

Main Station

Starter Sets
LocoNet®
Power Supplies



Your Digitrax LocoNet® Starter Set is just the beginning of an exciting trip! Pick the one that's right for you!



LocoNet®
The Digitrax
Difference

Locomotive Shops

Mobile Decoders
Function Decoders
SoundFX™ Decoders

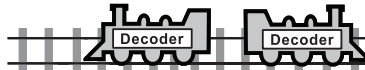

More Fun For Everyone

Add More Boosters, Advanced & Simple Throttles, Power Supplies, Universal Panels, IR and/or Radio for more trains and operators.

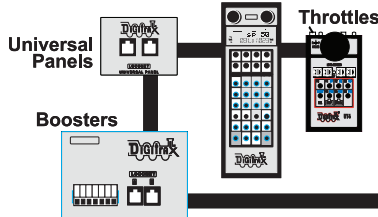

Maintenance Of Way

Make your layout more fun & simpler to operate!

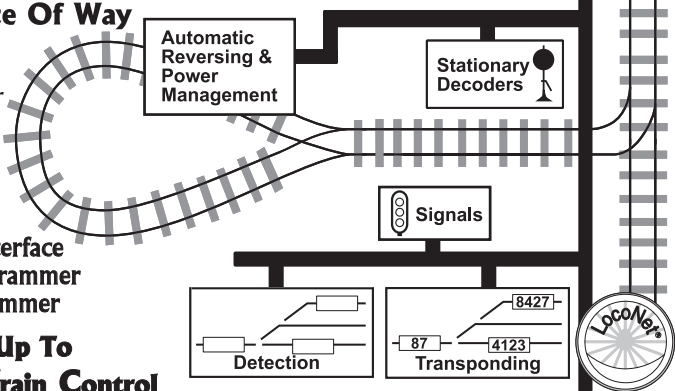

Computer Controls

Computer Interface
Decoder Programmer
Sound Programmer

It All Adds Up To Complete Train Control



2443 Transmitter Road
Panama City, FL 32404
www.digitrax.com

SFX006



Made in the USA



Contact: www.digitrax.com/contact
Support: techsupport@digitrax.com
Repair: repair@digitrax.com

6 52667 20029 5