



Complete Train Control
Run Your Trains, Not Your Track!

LNC162

16 Ft LocoNet Cable 2 pack

LNC162 Contents:

- 2 x 16 FT LocoNet Cable with RJ12 plug on each end.
- Pre-tested
- Instruction Sheet

LocoNet, the Digitrax Difference

LocoNet is Digitrax's method of communication between LocoNet compatible devices on a model railroad layout. LocoNet Compatible devices are designed to work together on the network, and in some cases can also accept DCC commands from the track, but often go beyond the scope of simple DCC train control.

LocoNet is a peer-to-peer Ethernet type multiple access network. Because of its design architecture, it is very robust and powerful. Layout implementation is simple and wiring is free form with minimal limits.

LocoNet is designed to run an unshielded 6 conductor ribbon cable. Digitrax recommends using flat, six-conductor telephone wire and RJ12 6P6C connectors for LocoNet wiring. This is a simple, cost effective way to wire LocoNet for excellent network performance and reliability.

Using shielded twisted pair conductors or Cat4, Cat5 and above will degrade LocoNet data performance and limit maximum wire footage that can be installed on the network. This type of wiring is not recommended by Digitrax because of its limitations.

The 6 LocoNet conductors are: two ground return connections (Pins 2 and 5), two data network signal connections for LocoNet message exchanges (pins 3 and 4), and two RailSync lines for signals that are mirror copies of the system DCC or other digital track control packets (pins 1 and 6).

With no message traffic, the two LocoNet data wires should measure approx. +12V DC with respect to LocoNet ground.

The RailSync lines communicate a copy of the track signals to the Boosters for amplification and transmission to the rails. RailSync lines can

power a limited number of LocoNet connected devices on small layouts. As the number of power consuming LocoNet devices attached to LocoNet increases, the need to separately power those devices increases.

RailSync is a low power signal that mirrors the DCC packets on the rails. It is generated by the Command Station and sent out via LocoNet (pins 1 & 6) to devices such as Boosters, Occupancy Detectors and any other device which require RailSync to operate. Boosters receive the RailSync data, amplify or boost the signal and output it to the track. RailSync can also be used as a source of power for low current devices such as throttles.

The LocoNet data network capability can run on as few as 2 or 3 wires. Confusion may result in that the whole cable is termed a “LocoNet” cable but in fact carries the LocoNet data messages and also packet copy/connectivity functions.

Digitrax uses the following LocoNet Wiring Convention:

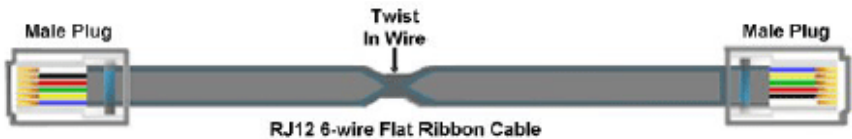
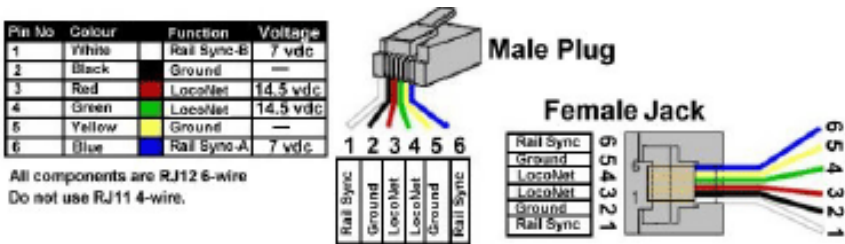

This arrangement is called a data cable in the telephone industry.

LocoNet Wiring: The Theory Behind the Practice

Digitrax recommends using the 6-wire configuration for the following

reasons:

1. In a 6 wire flat configuration, the left 3 wires are effectively a “mirror” image of the right 3 wires.
2. There are 2 Ground (pins 2 & 5) and 2 LocoNet data connections (pins 3 & 4), so the effective “loop resistance” is lower because of paralleled wires. This lets LocoNet run over greater distances.
3. If one ground or signal connection is broken or intermittent, the network can maintain a reliable connection.
4. The two outside wires (pins 1 & 6) carry opposite phase copies of the master system rail packets, this is called RailSync. RailSync allows LocoNet boosters and other LocoNet devices to be connected anywhere along a cable run. This works even with cable runs of thousands of feet and in the presence of noise and interference.
5. The balanced nature of the cable and the way the signal currents propagate in this “RF Quad” configuration generate the lowest possible RFI radiation and EMC susceptibility or inward interference pick-up. This is a good thing. This is part of the reason Digitrax LocoNet handily passes the FCC Class B radiation Certification requirements.
6. LocoNet’s philosophy and architecture allow “free-form” wiring with no termination or “linear-bus” restrictions. You can star, tee, branch, or expand LocoNet in any configuration. LocoNet can be used in any configuration except for a ring. You should NEVER connect LocoNet back on itself, because pins 1 and 6 should not be connected.

LocoNet Wiring: The Specifics

1. LocoNet supports a total cable length of up to about 2000 feet depending on actual wire type used and its capacitance.
2. No two devices should be connected by more than 1000 feet of cable.
3. LocoNet can be split & branched in any free form style.
4. The only network current pull up termination needed is provided by the Command Station. There should be only one Command Station the layout.
5. Do not loop LocoNet back on itself. Looping LocoNet back on itself causes RailSync (pins 1 and 6) to be shorted together and to be out of phase. This causes it to look like an overload to the driver circuit.
6. LocoNet works best when the network cables are 22AWG to 28AWG. The recommended 6 wire flat telephone type ribbon cable is 26AWG.
7. Plug and play design using 6 wire telephone type cables and RJ12 jacks makes setting up LocoNet quick and easy.
8. Plug in your LocoNet Cables in the same pin orientation around the layout for best results.

LocoNet Wiring: LocoNet Cables

LocoNet Cables must be reliable and well made, or you may see intermittent connectivity and spotty operation on the layout. If areas of the layout exhibit intermittent issues, bad cables may be the problem. Bad cables on your layout can be very frustrating and are completely avoidable by simply testing each cable before you install it on the layout.

It's easy to make LocoNet Cables. If you would rather purchase them, ready-made 6-pin male RJ12 to RJ12 cables of various lengths are available from sources such as DigiKey and Mouser. Be sure to use 6-conductor and not the similar 4-conductor plugs and wires. If you purchase pre-made cables, make sure you test them as described below before using them.

Tools You Will Need:

1. Quality RJ12 Crimping Tool
2. Quality 6 Conductor Flat Telephone Type Cable
3. RJ12 Connectors
4. Diagonal Cutters

Step by step instructions for making LocoNet cables:

1. Use quality tools and materials! Digitrax recommends against using plastic crimping tools, they can flex instead of crimping the wire to the connector.
2. Measure the length of the cable needed and cut the flat telephone cable with the diagonal cutters.
3. Using the crimping tool, strip the outside jacket from the telephone cable to expose the 6 individual wires inside the jacket.
4. Verify the order of the wires matches the diagram above (White, Black, Red, Green, Yellow and Blue).
5. Hold the cable with the freshly stripped end pointing away from you. Orient the cable so the White wire is on the left side of the cable.
6. Insert an RJ12 Connector on the cable. When inserting the connector, make sure the metal contacts are facing up and the tab is on the bottom.
7. Visually inspect the wires through the plastic to make sure the wires are still in the proper order.
8. Make sure the connector is inserted fully on the wire.
9. Place the cable and the connector into the 'crimp' portion of the crimper.
10. Compress the handles of the crimper to crimp the connector onto the cable.

11. A properly crimped cable has all the wires fully inserted into the connector, the strain relief contacting the outer jacket of the cable and the metal contacts making a connection with the individual wires.
12. Perform the same steps on the other end of the cable.

Test EVERY LocoNet Cable before installation as follows:

1. Commercial cable testers can be used to test LocoNet Cables. Follow the instructions provided with the cable tester to test cables without connecting them to LocoNet. Once the test is completed good, cables can be installed on the layout.
2. Every Digitrax Starter Set includes an LT1 for testing LocoNet cables. LT1 LocoNet Testers can also be purchased separately.



3. Plug one end of the cable being tested into the LT1
4. Plug the other end of the LocoNet cable being tested into LocoNet
5. Turn on Track Power using a throttle.
6. Make sure address 00, the analog loco address, is set to 0 speed.
7. Leave the throttle plugged in to LocoNet.
8. If the cable is good ALL 4 LEDs will glow.
 - a. LED 1 checks RailSync White & Black wires
 - b. LED 2 checks LocoNet Black & Red wires
 - c. LED 3 checks LocoNet Green & Yellow wires
 - d. LED 4 checks RailSync Yellow & Blue wires
9. If any of the LEDs fail to glow or are dim, cut the ends off the cable and crimp new connectors on the cable. Re-test the cable. If it still fails the test, there may be a problem with the cable itself and you should consider discarding it.
10. DO NOT leave the LT1 connected to a running layout, because it adds an extra unnecessary load LocoNet. It is meant to be used as a simple temporary diagnostic tool.

LocoNet Jacks

LocoNet Cables are plugged into LocoNet Jacks located around the layout. LocoNet Jacks are available on all LocoNet compatible components.

Shorted Contacts Inside LocoNet Jacks Can Cause LocoNet Problems:

1. If the contacts inside the LocoNet jacks are accidentally shorted, LocoNet may exhibit strange behavior or may stop working all together.

2. It's easy to see if these contacts are shorted by simply looking inside the jack.
3. If contacts are shorted inside the LocoNet Jack, simply straighten them so they are no longer touching.
4. If contact 3 or 4 is shorted to contact 2 or 5 (ground), the Command Station will not see LocoNet messages and LocoNet will appear unresponsive.
5. If contact 1 or 6 is shorted the Boosters may not make good track packets or power reductions to throttles and other devices may brown out and not operate properly.

Digitrax UP5 and other previous models of Universal Panels are very convenient for quick LocoNet hook up.

LocoNet Jacks and Throttle Jacks: All Jacks are NOT created equal:

1. LocoNet Jacks, like the ones on the back of all UP5s, are used for hooking up the LocoNet backbone. Additional LocoNet devices can be daisy chained from LocoNet jacks.
2. LocoNet Throttle Jacks, like the ones on the front and sides of all UP5s, for hooking up additional throttles or LocoNet devices that won't be daisy chained to other devices. Additional LocoNet devices should NOT be daisy chained from Throttle Jacks.

Boosters and Command Stations

Multiple command stations on the layout will cause control confusion and loss of reliable layout control. Basically, if things just are not operating correctly, trains don't want to run, track power is questionable then check to make sure that a Command Station capable device, such as a DCSxxx, that has been set up to run as a booster using Option Switches hasn't been switched back to being a command station at power up.

1. A layout should have only ONE command station.
2. Power each Command Station and Booster with its own power supply that is properly rated for the device being powered. Note the PS2012 can be split to power multiple boosters.
3. Command stations that are powered up and then added to an existing powered layout may cause problems because they will not be able to detect an existing competing command station already present on the layout.
4. If using a Command Station as a Booster by setting Option Switches, be certain it is operating as booster by setting the OpSw after powering up the unit to avoid layout control problems.
5. Track must be double gapped between booster districts.

LocoNet & RailSync Voltages

If either LocoNet or RailSync voltage is too low, the layout may experience several different symptoms. It may have difficulty in turning on track power to additional Boosters. Throttles may not operate correctly or may have no display at all if they do not have a battery installed. Detection and/or Transponding may not operate correctly.

Use a good quality Digital Voltmeter (DVM) to help diagnose:

1. If the 2 LocoNet data lines (pins 3 & 4, green/red) have voltage between 8V and 14V with no message traffic present. This confirms that the booster is outputting enough voltage.
2. If the RailSync lines are OK. The two RailSync lines are driven as anti-phase copies of the track digital signal, and are driven with a 22 ohm output impedance so as they are loaded the voltages will drop, indicating the current load. These two lines should not be connected together, and this will cause excess current draw and low voltages.

How to Check for Low LocoNet Voltage

1. Prepare a short LocoNet cable with one end stripped to expose the wires inside the jacket.
2. Strip the Red and Green wires and twist them together.
3. Strip the Black and Yellow wires and twist them together.
4. Plug this short LocoNet cable directly into one of your command station's LocoNet Ports.
5. Disconnect LocoNet from the layout at your Command Station so that you are measuring LocoNet voltage at the Command Station without the layout attached.
6. Use a good quality multimeter (in the 20 volt DC range) to measure the DC voltage between the red/green and black/yellow pairs.
 - a. Connect the red/green wires to the +ve lead of the DVM and the -ve DVM lead black/yellow wires and measure the voltage.
7. The voltage on the LocoNet data wires should be at least +8V DC. The highest voltage depends on the command station but is usually +12V to +14V

Very large layouts will benefit from using a LocoNet Repeater (LNRP)

If more than 40 devices are on a single leg of LocoNet, or you get frequent interruptions as you plug in devices, this may indicate the need for

an LNRP.

1. LocoNet Repeaters can be used to isolate areas of the layout from each other
2. Allows for troubleshooting with LocoNet fault indications
3. Proper operation of LNRP REQUIRES at least a 14VDC power supply.

How to Check RailSync for Low Voltage

How to Check RailSync for Low Voltage

1. Use the short LocoNet cable prepared for checking LocoNet voltage above.
2. Plug this short LocoNet cable directly into one of your command station's LocoNet Ports.
3. Disconnect LocoNet from the layout at your Command Station so that you are measuring RailSync voltage at the Command Station without any of the layout attached.
4. Measure the Unloaded RailSync voltage at the Command Station without the layout plugged in. Measure both RailSync voltages separately and add them to remove and analog zero stretching changes and to be sure both wires are carrying RailSync:
 - a. Use a DVM to measure from the white wire pin1 to black or the yellow ground (pin 2 or 5).
 - b. Use a DVM to measure from the blue wire pin 6 to the black or yellow ground (pin 2 or 5).
 - c. Add these two DC voltages, the total should be a voltage of +12V to +14V DC, with the command station unplugged from the layout. This is the unloaded RailSync measurement.
5. Measure the Loaded RailSync Voltage at the Command Station with the layout plugged back in to the Command Station
 - a. Plug the LocoNet Cable from the layout in to the Command Station.
 - b. Again, use a DVM to measure from the white wire pin1 to the black or yellow ground (pin 2 or 5) on the short LocoNet Cable plugged in to the Command Station.
 - c. Use a DVM to measure from the blue wire pin 6 to the black or yellow ground (pin 2 or 5).
 - d. Add these two DC voltages, the total should be a voltage of +7 volts DC, with the command station plugged into the layout. This is the loaded RailSync measurement
6. Compare the Unloaded and Loaded measurements for RailSync; this voltage difference is a measure of how much power the RailSync loads are drawing.

7. If voltage is below 8 volts, make sure all UR92s, UR91s, PM42s, etc. are powered using PS14 or similar power supplies as required.
8. If this does not bring the voltage above 8 volts, power all throttles with batteries and/or power UP5 and similar panels using PS14. Multiple UP panels can share a single power supply by daisy chaining them together as shown in their instruction sheets.



LNC162
16 Ft LocoNet Cable 2 pack

Go Beyond DCC With Digitrax® Complete Train Control

Main Station

Starter Sets
LocoNet®
Power Supplies

**DUPLEX
EQUIPPED**
Available

Your Digitrax LocoNet® Starter Set is just the beginning of an exciting trip! Pick the one that's right for you!



LocoNet®
The Digitrax
Difference

Locomotive Shops

Mobile Decoders
Function Decoders
SoundFX™ Decoders

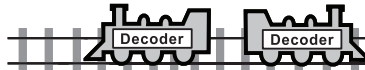

More Fun For Everyone

Add More Boosters, Advanced & Simple Throttles, Power Supplies, Universal Panels, IR and/or Radio for more trains and operators.

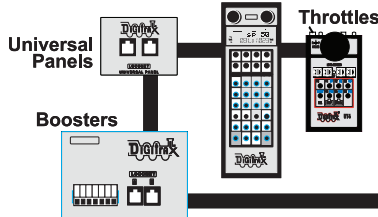

Maintenance Of Way

Make your layout more fun & simpler to operate!

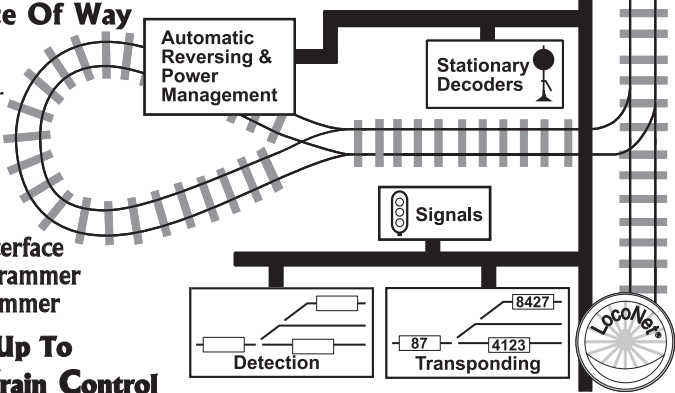

Computer Controls

Computer Interface
Decoder Programmer
Sound Programmer

It All Adds Up To Complete Train Control



2443 Transmitter Road
Panama City, FL 32404
www.digitrax.com

Made in the USA



Contact: www.digitrax.com/contact
Support: techsupport@digitrax.com
Repair: repair@digitrax.com

LNC162



6 52667 18007 8