



DH165K0

Fits Kato, Stewart, Atlas & Other
HO Locomotives

HO Scale

Mobile Decoder
Circuit Board Replacement
SFX SoundBug™ compatible
1 Amp/2 Amp Peak
6 FX3 Functions, 0.5 Amp

Features:

- **Accepts Plug-in SFX SoundBug™ sound modules**
- **Regulated Headlights:** convenient no-resistor install of LEDs and lamps.
- **Digitrax LocoMotion® System-**Your locomotives look like the real thing. The Digitrax LocoMotion System makes them run like the real thing, too!
 - Torque Compensation** for smooth as silk silent operation.
 - 128 Speed Step** operation (14 or 28 steps can also be used).
 - Momentum** with acceleration and deceleration.
 - Normal Direction of Travel** is user selectable.
 - Switching Speed** feature for easier and faster access to yard speeds.
 - 3 Step Speed Tables** set start, mid and max voltage for custom control.
 - 28 Step Speed Tables** with 256 level resolution for precise control.
- **Scalable Speed Stabilization** with simple setup & 1024 level resolution.
- **SuperSonic** motor drive for silent operation.
- **FX³ Functions** for prototypical lighting effects:
 - Constant Brightness Lighting** directional or independent control.
 - Realistic Effects** like Ditch lights, Mars lights, strobes, and many more.
 - Dynamic and Static Qualifiers** operate functions based on direction, F0 on or off, loco direction and F0, and whether loco is moving.
 - Function Remapping** for custom function setup.
 - Master Light Switch** turns off all lights & functions with one keystroke.
 - Advanced Consist Function Controls**
- **Transponder equipped** ready for transponding on your layout.
 - Compatible with digital surround sound systems
- **All Mode Programming with Operations Mode Read Back-**read back CV values right on the mainline.
- **Decoder Factory CV Reset** with or without speed table initialize.
- **Motor Isolation Detection** prevents damage to your decoder.
- **Basic, Advanced & UniVersal Consisting**
- **2 Digit and 4 Digit Addressing**
- **DCC Compatible**

Parts List

1 DH165K0 Decoder

1 Instruction sheet

Installation Information

See the Digitrax Decoder Manual for complete decoder test procedures, installation instructions, programming and technical information. Digitrax manuals and instructions are updated periodically. Please visit www.digitrax.com for the latest versions, technical updates and additional locomotive-specific installation instructions.

Installation Instructions - Kato HO Scale GP35 example

1. Carefully remove the locomotive's shell from the frame. Note the orientation for proper reinstallation. (*Figure 1*)

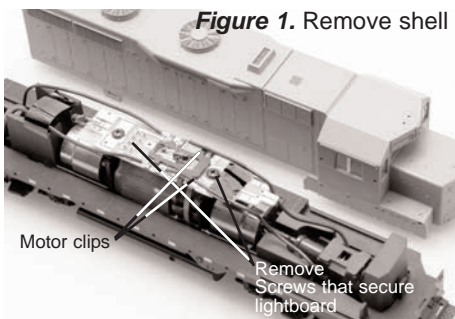

2. Remove the four track power pickup wires clipped to the lightboard (2 on each side) (*Figure 2*) Carefully pull the brass motor clips from under the track power 'staples' on the lightboard.
3. Unscrew the lightboard screws to release PCB from the frame.

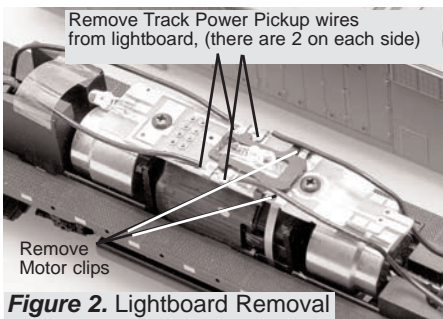

Decoder Board Installation

4. Physically secure the DH165K0 decoder PCB with the lightboard screws.
5. Attach the four track power pickup wires by shortening and stripping each wire (2 on each end) and soldering these wires to each corner of the decoder PCB as shown (*Figure 3*)
6. Reattach the brass motor clips through the motor "staples" on the decoder (*Figure 4*) .
7. Solder white LEDs at "alternate F0" location in PCB center and at locomotive rear. The LED anodes/+ go to "blue" pads. You can use the original LEDs.
8. Replace the locomotive shell.

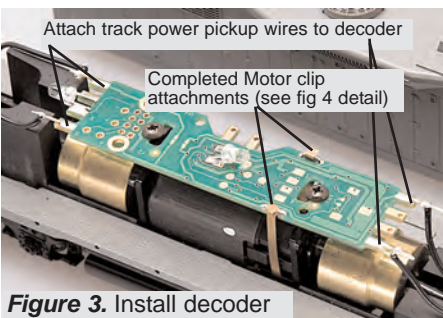

- Digitrax decoders are set up with configuration variable (CV) factory settings so you can run your locomotive using address 03. This installation will allow the loco to run short hood forward. To run this loco long hood forward with lights coming on in both directions, change the Normal Direction of Travel CV29=07 and then remap FOR CV34=01 to make the headlight come on when the locomotive travels in reverse.

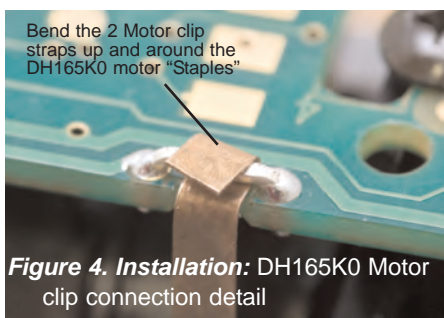

Customizing Your Decoder

All Digitrax decoders can be customized for realistic operation. The most commonly used CVs, their default values and uses are listed below. The Digitrax Decoder Manual, available on line at www.digitrax.com, contains complete information on these and other CVs and CV values available.

Changing the Decoder Address

The first CV most people change is the decoder address so that the loco can be independently controlled with it's own unique address. All Digitrax decoders are shipped with CV01 (AD2), the two digit address, set to 03. See your Starter Set Manual for complete programming instructions. Following is a brief description of how to change the decoder address with a DT series throttles.

- Place the loco on the programming track. Go into Program Mode on your system. On DT400 press PROG. On DT300, DT100 & DT200 press RUN/STOP & FN/F0.
- Choose AD2 for 2 digit addressing or AD4 for 4 digit addressing (DT300 & DT400). (Ad for DT100 & DT200, see set manual for 4 digit instructions).
- Choose the address you want to set up for the decoder.
- Complete address programming. On DT400 press ENTER. On DT300, DT100 & DT200 press SEL.

Note: CV29 must also be programmed to enable 4 digit addressing, this is done automatically by the DT300 & DT400 but not on earlier throttles.



Digitrax LocoMotion® System

Your locomotives look like the real thing, now you can make them run like the real thing, too. Digitrax decoders incorporate torque compensation for smooth as silk operation. You can also program CVs that control momentum, 3 step and 128 step speed tables, switching speed, normal direction of travel, scaleable speed stabilization and more to take full advantage of the Digitrax LocoMotion System.

Momentum-CV03 & CV04

Acceleration is controlled by CV03 and deceleration by CV04. Both come from the factory set to 000/x00. A range of 000/x00/ to 031/x1F is available for both accel and decel. We recommend that you try CV03:003/x03 and CV04:000/x00 as a starting point for experimenting with momentum.

Speed Tables-How the Loco Responds to the Throttle

There are two types of speed tables: 3 Step Tables and High Resolution 28 Step Tables. Please see your Decoder Manual for a discussion of the 28 Step Tables. The 3 Step Tables are set up by programming 3 CVs: Start Voltage (CV02), Mid point Voltage (CV06) and Max Voltage (CV05). These values are set at 000/x00 at the factory. All have a range of values from 000/x00 to 255/xFF. We recommend the following CV values as a starting point for experimenting with speed tables.

Loco Type	V Start CV02	V Mid CV06	V Max CV05
Switcher Concentrated low speed. Limited top speed	002/x02	038/x26	064/x50
Road Switcher Prototypical top speed w/evenly distributed curve from 0 to top speed	002/x02	048/x30	098/x62
Mainline Loco Quick increase to cruising speed then levels off to prototypical top speed.	002/x02	128/x80	154/x9A



Other Locomotion® Features: Switching Speed, Normal Direction of Travel & Scaleable Speed Stabilization (Back EMF) Features

Switching speed is controlled by CV54. The factory setting is 000/x00 for OFF. To turn on the switching speed feature, program CV54 to a value of 001/x01. When this feature is on, use F6 to activate and deactivate switching speed. When switching speed is ON and F6 is ON, the switching speed feature is on. With the feature on the throttle's target speed is effectively reduced by about 50% and the effects of accel and decel programmed into the decoder are reduced by 1/4. This is useful for yard switching operations.

Normal Direction of Travel is controlled by CV29 bit 0.

The intensity of **Scaleable Speed Stabilization (Back EMF)** is controlled by CV57. The default value for this feature is 006/x06 which is suitable for most locos. You can adjust this value in the range of 000/x00 for OFF to 015/x0F for the maximum effect. Consult your Decoder Manual for info about CVs 55 & 56 and their effects on scaleable speed stabilization.

SuperSonic Silent Operation and Torque Compensation

The factory settings in the decoder provide silent, smooth operation of your locomotive under most conditions. For more information about these settings, please see the Digitrax Decoder Manual or our web site.

Digitrax Transponding CV61

Digitrax Transponding is controlled by CV61. The initial factory set value is 000/x00 for OFF. To turn ON transponding, program CV61 to a value of 002/x02. This allows you to use Digitrax transponding to keep track of your rolling stock. When transponding is enabled, the front light of the locomotive will flicker slightly to indicate transponding signal is being communicated. For optimal transponding operation, we recommend that you hook up the forward and rear lights using the standard installation instructions.

Decoder Reset CV08

Decoder reset lets you reset all CV values to the initial factory settings. To reset all CV values, program CV08 to a value of 008/x08. You also have the option of resetting all values except the 28 speed step tables. To do this, program CV08 to a value of 009/x09.

Functions on the DH165K0

The DH165K0 is set up at the factory to control six function outputs.

The DH165K0 is configured to control the forward-headlight F0F/white lead and reverse-headlight F0R/yellow lead for directional lighting. These two headlight function leads are current regulated for LEDs or lamps, with factory setting of approx 15mA, with no resistors required. Cut the ADJ link to increase headlight current to approx 30mA- see fig 5.

Functions F1 (Green), F2 (Violet), F3 (Brown) and F4 (White/Yellow) are full track voltage and can be used by soldering a wire from the pad for the function you wish to use to the lamp (or other function) you wish to control. The wire colors indicated are the standard color code used in the industry (you can use any color you like). These colors are important if you plan to use function remapping.

CAUTION: When adding function wires, be very careful that the wires you add do not come into contact with any other pads or components on the board where they might create a short circuit.

All six function outputs can be easily set up with Digitrax FX³ lighting effects or as standard on/off functions with the following operational qualifiers:

1. Forward or Reverse direction of travel, or
2. Whether F0 is on or off, or
3. Both direction of travel and whether F0 is on or off, or
4. Whether the locomotive is stopped or moving.

Figure 5. DH165K0 Decoder Function Outputs (front of loco to the right)

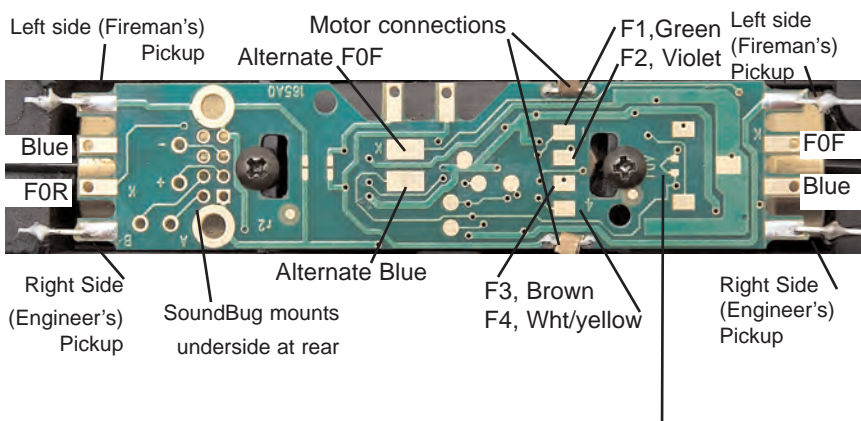

Lighting ADJ option: Cut this '>' pathway for 30 milliamp applications such as large lamps, etc. Leaving the '>' intact provides 15 milliamp outputs for LEDs and smaller lamps (on F0F/F0R only). Other functions may require resistors!



2443 Transmitter RD
Panama City, FL 32404
www.digitrax.com

T 850-872-9890
F 850-872-9557
E sales@digitrax.com

Function Mapping

Function remapping allows you to program the function outputs of your decoder to be controlled by selected function keys on your throttle. Please consult the Digitrax Decoder Manual or web site for information on function remapping.

Digitrax Transponding CV61

Digitrax Transponding is controlled by CV61. The default value is 000/x00 for OFF. To turn on transponding, program CV61 to a value of 002/x02. This allows you to use Digitrax transponding to keep track of your rolling stock.

Decoder Reset CV08

Decoder reset lets you reset all CV values to the factory settings. To reset all CV values, program CV08 to a value of 008/x08. You also have the option of resetting all values except the 28 speed step tables. To do this, program CV08 to a value of 009/x09.

Warranty & Repair

All warranties on Digitrax products are limited to refund of purchase price, repair or replacement at Digitrax's sole discretion. Except as expressly stated in the full warranty statement, there are no warranties, express or implied, including but not limited to any warranties of merchantability or fitness for a particular purpose. For complete warranty details see www.digitrax.com.

Damaged decoders should be returned directly to Digitrax for repair.

Digitrax, Inc. is not responsible for unintentional errors or omissions in this document.



DH165K0

Board Replacement Decoder Fits Many Kato Diesel H0 Scale Locomotives

Go Beyond DCC With **Digitrax** Complete Train Control

Main Station

Starter Sets
LocoNet®
Power Supplies



Your Digitrax LocoNet® Starter Set is just the beginning of an exciting trip!
Pick the one that's right for you!



LocoNet®
The Digitrax Difference

Locomotive Shops

Mobile Decoders
Function Decoders
SoundFX™ Decoders



More Fun For Everyone

Add More Boosters, Advanced & Simple Throttles, Power Supplies, Universal Panels, IR and/or Radio for more trains and operators.

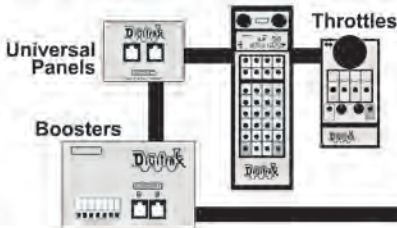

Maintenance Of Way

Make your layout more fun & simpler to operate!

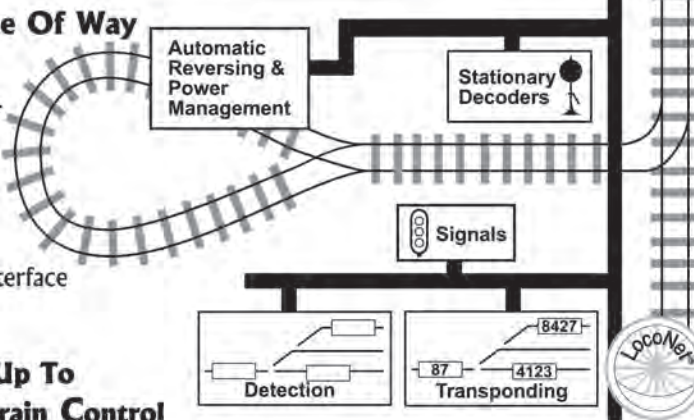

Computer Controls

Computer Interface Programmer

It All Adds Up To Complete Train Control



2443 Transmitter Road
Panama City, FL 32404
www.digitrax.com
T 850-872-9890
F 850-872-9557
E sales@digitrax.com

Made in U.S.A.



DH165K0



6 52667 05047 0