



Digitrax Command Control
Run Your Trains, Not Your Track!

DH165IP

Fits Many HO Locomotives
with DCC 8pin Medium Socket

HO Scale

Mobile Decoder
DCC Plug 'N Play
1.0 Amp/1.5 Amp Peak
6 FX³ Functions, 0.5 Amp

Features:

- **Compatible with SFX sound modules**
- **Digitrax LocoMotion[®] System**-Your locomotives look like the real thing. The Digitrax LocoMotion System makes them run like the real thing, too!
 - Torque Compensation** for smooth as silk silent operation.
 - 128 Speed Step** operation (14 or 28 steps can also be used).
 - Momentum** with acceleration and deceleration.
 - Normal Direction of Travel** is user selectable.
 - Switching Speed** feature for easier and faster access to yard speeds.
 - 3 Step Speed Tables** set start, mid and max voltage for custom control.
 - 28 Step Speed Tables** with 256 level resolution for precise control.
- **Scaleable Speed Stabilization (Back EMF)** with simple setup & 256 level resolution.
- **SuperSonic** motor drive for silent operation.
- **FX³ Function** outputs for prototypical lighting effects and on/off control:
 - Constant Brightness Lighting** with directional or independent control.
 - Realistic Effects** like Ditch lights, Mars lights, strobes, and many more.
 - FX³ & Standard Function Qualifiers** operate functions based on direction, F0 on or off, direction and F0, and whether loco is moving.
 - Function Remapping** of 14 functions for custom function setup.
 - Master Light Switch** turns off all lights & functions with one keystroke.
 - Advanced Consist Function Controls**
- **Plug 'N Play** design makes installation quick and easy.
- **Digitrax 5-Pin Function Plug compatible** for added convenience.
- **Transponder equipped** ready for transponding on your layout.
- **All Mode Programming with Operations Mode Read Back** reads back CV values right on the mainline.
- **Decoder Reset CV** with or without speed table reset.
- **Motor Isolation Protection** prevents damage to your decoder.
- **Basic, Advanced & UniVersal Consisting**
- **2 Digit and 4 Digit Addressing**
- **DCC Compatible**

Parts List

1 DH165IP Decoder

1 Instruction sheet

Installation Information

See the Digitrax Decoder Manual for complete decoder test procedures, installation instructions, programming and technical information. Digitrax manuals and instructions are updated periodically. Please visit www.digitrax.com for the latest versions, technical updates and additional locomotive-specific installation instructions.

Installation Instructions - Kato HO-Scale EMD SD70MAC Locomotive

1. Carefully remove the locomotive shell (*Fig. 1*) noting the orientation of the shell to the frame for reinstallation.
2. Remove the two metal jumper plugs in the locomotive's DCC-ready socket. (*Figure 2*) The jumper plugs allow the locomotive to operate on a standard DC track or in analog mode on a DCC track.
3. Plug the DH165IP decoder into the socket making sure that pin one is plugged into the socket marked 1. (*Fig. 3*) Pin 1 on the decoder has a square pad. Seat the decoder firmly in the socket.
4. Replace the loco shell on the frame. The loco is now ready to run on your DCC system using the factory set address 03. See next page for customizing.
5. Some locomotives employ motor filter capacitors in the locomotive wiring. These may cause problems with Supersonic decoders and analog operation on DCC. This capacitor should be removed for safe operation.



Figure 1. Remove loco shell.

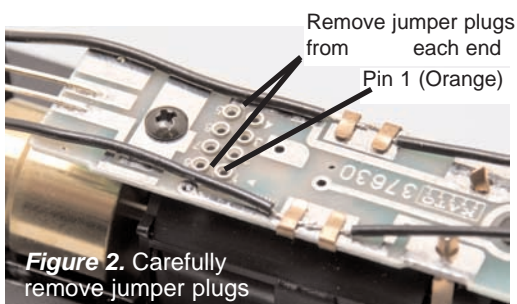

Figure 2. Carefully remove jumper plugs

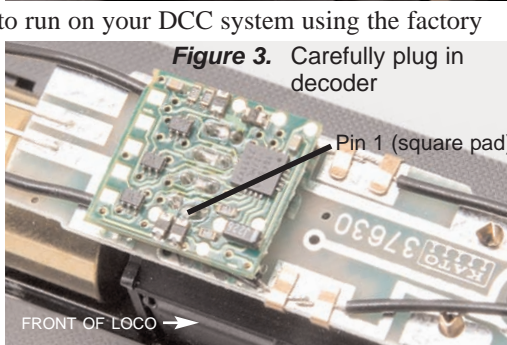

Figure 3. Carefully plug in decoder



Customizing Your Decoder

Your Digitrax decoder is ready to run and will operate using address 03 with no additional programming. However, for a more prototypical railroading experience, your decoder can be customized for your specific locomotive and layout requirements by programming some of the many Configuration Variables, or CVs, available. Some of the most commonly used CVs, their factory settings and uses are listed below. The Digitrax Decoder Manual, available on line at www.digitrax.com, contains complete information on how to use these and other CVs and the range of CV values available.

Changing the Decoder Address

The first CV most people change is the decoder address. This allows you to independently control each loco with a unique address. Digitrax decoders are shipped with CV01 (AD2), the two digit address, set to 03. Following is a brief description of how to change the decoder address with a Digitrax DT series throttle. See your Starter Set Manual for complete programming instructions.

- 1 Place the loco on the programming track. Go into Program Mode on your system. On DT400 press **PROG**. On DT300, DT100 & DT200 press **RUN/STOP & FN/F0**.
2. Choose AD2 for 2 digit addressing or AD4 for 4 digit addressing (DT300 & DT400). (Ad for DT100 & DT200, see set manual for 4 digit instructions).
3. Choose the address you want to set up for the decoder.
4. Complete address programming. On DT400 press **ENTER**. On DT300, DT100 & DT200 press **SEL**.

Note: CV29 must also be programmed to enable 4 digit addressing, this is done automatically by the DT300 & DT400 but not on earlier throttles.

Digitrax LocoMotion® System

Your locomotives look like the real thing, now you can make them run like the real thing, too. Digitrax decoders incorporate torque compensation for smooth as silk silent operation. You can also program CVs that control momentum, 3 step and 128 step speed tables, switching speed, normal direction of travel, scaleable speed stabilization and more to take full advantage of the Digitrax LocoMotion System.

Momentum-CV03 & CV04

Momentum is part of the LocoMotion System. Acceleration is controlled by CV03 and deceleration by CV04. Both come from the factory set to 000/x00. A range of 000/x00/ to 031/x1F is available for both accel and decel. We recommend that you try CV03:003/x03 and CV04:000/x00 as a starting point for experimenting with momentum.



Speed Tables-How the Loco Responds to the Throttle

With Digitrax LocoMotion, there are two types of speed tables: 3 Step Tables and High Resolution 28 Step Tables. Please see your Decoder Manual for a discussion of the 28 Step Tables. The 3 Step Tables are set up by programming 3 CVs: Start Voltage (CV02), Mid point Voltage (CV06) and Max Voltage (CV05). These values are set at 000/x00 at the factory. All have a range of values from 000/x00 to 255/xFF. We recommend the following CV values as a starting point for experimenting with speed tables.

Loco Type	V Start CV02	V Mid CV06	V Max CV05
Switcher Concentrated low speed. Limited top speed	002/x02	038/x26	064/x50
Road Switcher Prototypical top speed w/evenly distributed curve from 0 to top speed	002/x02	048/x30	098/x62
Mainline Loco Quick increase to cruising speed then levels off to prototypical top speed.	002/x02	128/x80	154/x9A

Other LocoMotion® Features: Switching Speed, Normal Direction of Travel & Scaleable Speed Stabilization (Back EMF) Features

Switching speed is controlled by CV54. The factory setting is 000/x00 for OFF. To turn on the switching speed feature, program CV54 to a value of 001/x01. When this feature is on, use F6 to activate and deactivate switching speed. With the feature on the throttle's target speed is effectively reduced by about 50% and the effects of accel and decel programmed into the decoder are reduced by 1/4. This is useful for yard switching operations.

Normal Direction of Travel is controlled by CV29. See your decoder manual for additional information on the settings for CV29.

Scaleable Speed Stabilization intensity, or droop, is controlled by CV57. The factory setting for this feature is 006/x06 which is suitable for most locos. You can adjust this value in the range of 000/x00 for OFF to 015/x0F for the maximum effect. Consult your Digitrax Decoder Manual for info about CVs 55 & 56 and their effects on scaleable speed stabilization.

SuperSonic Silent Operation and Torque Compensation

The factory settings in the decoder provide silent, smooth operation of your locomotive under most conditions. For more information about these settings, please see the Digitrax Decoder Manual or our web site.

Function Outputs on the DH165IP

The DH165IP has six function outputs available. The DH165IP is configured to control the lights on the factory light board through the integrated DCC 8-pin plug using Function 0 (F0F-forward and F0R-reverse) for directional lighting. Function outputs F1/Green, F2/Violet, F3/Brown and F4/White/Yellow are available on the decoder and can be used by soldering wires from the pads indicated to additional lights (or other functions) you wish to control.

CAUTION: When adding function wires, be very careful that the wires you add do not come into contact with any other pads or components thus creating a short circuit.

All six function outputs can be programmed as Digitrax FX³ lighting effects or as standard on/off functions. All the function leads will switch loads connected to the track voltage available from the Blue/+common lead

All function outputs can be qualified based on:

1. Forward or Reverse direction of travel, or
2. Whether F0 is on or off, or
3. Both direction of travel and whether F0 is on or off, or
4. Whether the locomotive is stopped or moving.

Figure 4. DH165IP Decoder Function Outputs

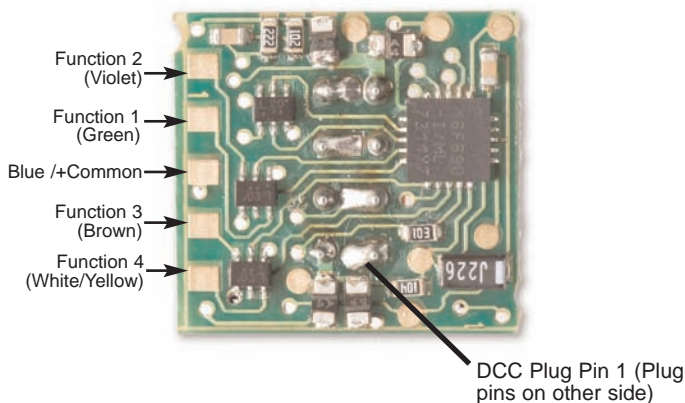

Master Light Switch

Each of the six function outputs can be programmed to turn on and off with the F0 ON/OFF key on your throttle, creating a Master Light Switch. The CV values for creating this effect are listed in the Digitrax Decoder Manual in the section: *Setting Up FX & FX³ Effects On Function Outputs.*

Function Remapping

Function remapping allows you to program the function outputs of your decoder to be controlled by selected function keys on your throttle. Please consult the Digitrax Decoder Manual or website for information on function remapping.

Quick Start for Digitrax FX³ Lighting Effects for the Kato SD70MAC

The prototype of the Kato HO EMD SD70MAC, uses ditch lights in conjunction with the headlight. To set up ditch lights on your locomotive follow these instructions:

1. Install the DH165IP decoder in the locomotive (see page 2), test for proper operation.
2. Cut the light pipe assembly as shown in **Figure 5**. You will end up with two separate light pipes: one for each of the ditch lights.

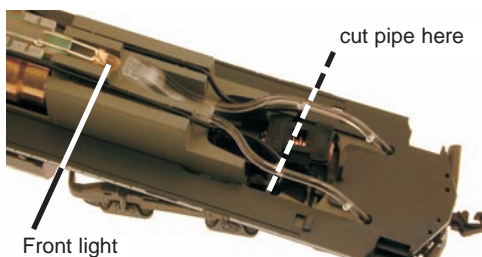

Figure 5. Light pipe modification

3. Install two incandescent 1.5V/15mA lamps (or LEDs) as shown in **Figure 6&7**. A 1Kohm 1/4W resistor should be soldered inline with the lead to each light/LED. *The resistor value should be selected to set the desired level of brightness of the lights used.* Slide a short length of shrink wrap on each lead to cover the resistor. The leads from the lamps or LEDs are soldered to F1/Blue pads on the decoder (**Figure 4**) for the left ditch light and F2/Blue pads for the right ditch light. The Blue (+Common) wire is soldered to the middle pad on the decoder. The

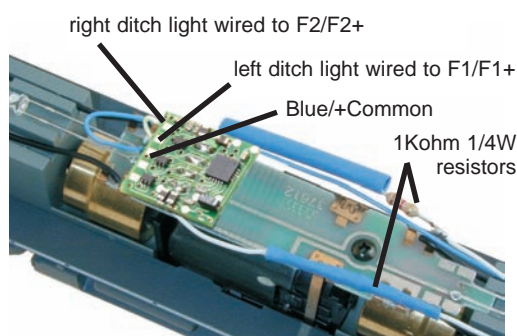

Figure 6. LED installation

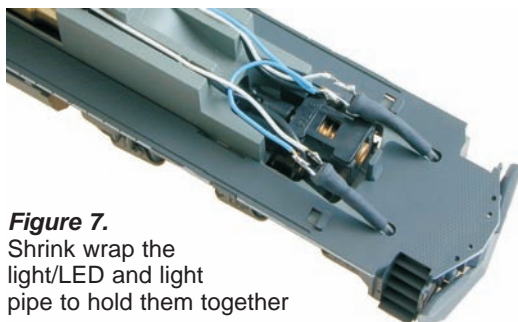

Figure 7. Shrink wrap the light/LED and light pipe to hold them together



+ve/anode leads of LEDS will be connected to the Blue pad.

4. Use a short piece of shrink wrap tubing to attach the LED to the cut end of the light pipe. Slide one end over the LED and the other end onto the light pipe to hold the two parts together. (*Figure 7*)
5. Program CV51 to a CV value of 107/x6B and CV52 to a CV value of 106/x6A to turn ditch lights on while running forward and F0 is on. When F2 is on, ditch lights will flash alternately to simulate operation at grade crossing. F2 is a momentary function on Digitrax throttles so that as long as the key is held down, the function operates & when released, it goes off. This simulates blowing the horn at a grade crossing causing ditch lights to be activated, as commonly done by a number of railroads.
6. Program CV62 to a value of 196/xC4 to set the ditch light rate. Program CV63 to a value of 064/x40 to set a realistic ditch light hold over time after the release of F2 function key.

Note: See the current Digitrax Decoder Manual or web site to learn more about FX³ effects.

Digitrax Transponding CV61

Digitrax Transponding is controlled by CV61. The initial factory set value is 000/x00 (OFF). To turn on transponding, program CV61 to a value of 002/x02. This allows you to use Digitrax transponding to keep track of your rolling stock. When transponding is enabled, the front light of the locomotive will flicker slightly to indicate that a transponding signal is being communicated.

Decoder Reset CV08

Decoder reset lets you restore all CV values to their initial factory settings. To reset all CV values, program CV08 to a value of 008/x08. To reset all CV values EXCEPT for the values entered in your 28 speed step tables, program CV08 to a value of 009/x09.

Warranty & Repair

All warranties on Digitrax products are limited to refund of purchase price, repair or replacement at Digitrax's sole discretion. Except as expressly stated in the full warranty statement, there are no warranties, express or implied, including but not limited to any warranties of merchantability or fitness for a particular purpose. For complete warranty details see www.digitrax.com.

Damaged decoders should be returned directly to Digitrax for repair.

Digitrax, Inc. is not responsible for unintentional errors or omissions in this document.



DH165IP

HO Locos with DCC Ready Medium Socket

Go Beyond DCC With



Complete Train Control

Main Station

Starter Sets
LocoNet®
Power Supplies



Your Digitrax LocoNet® Starter Set is just the beginning of an exciting trip!
Pick the one that's right for you!



LocoNet®
The Digitrax Difference

Locomotive Shops

Mobile Decoders
Function Decoders
SoundFX™ Decoders

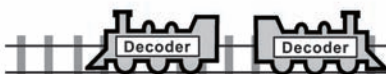

More Fun For Everyone

Add More Boosters, Advanced & Simple Throttles, Power Supplies, Universal Panels, IR and/or Radio for more trains and operators.

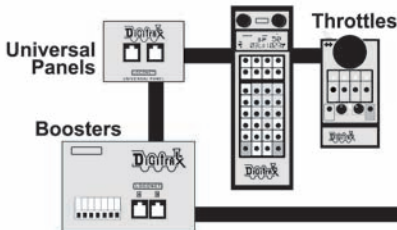

Maintenance Of Way

Make your layout more fun & simpler to operate!

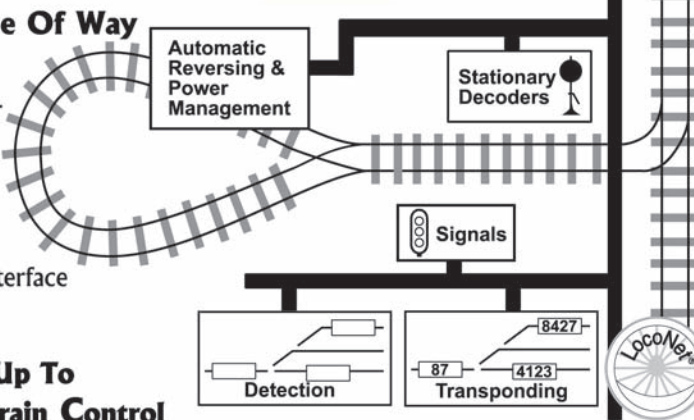

Computer Controls

Computer Interface Programmer

It All Adds Up To Complete Train Control



450 Cemetery Street
Norcross, GA USA 30071
www.digitrax.com
T 770-441-7992
F 770-441-0759
E sales@digitrax.com

Made in U.S.A.



DH165IP



6 52667 05054 8