



DH126PS

Fits Many HO Locomotives

.672" x 1.074" x .259"

17.08mm x 27.28mm x 6.6mm

HO Scale

Mobile Decoder

Digitrax Easy Connect 9 Pin to DCC

Medium Plug 1.0" harness

1.5 Amp/2 Amp Peak

2 FX³ Functions, 0.5 Amp

Features:

- **FX³ Function outputs** for prototypical lighting effects and on/off control:
 - Constant Brightness Lighting** with directional or independent control.
 - Realistic Effects** like Ditch lights, Mars lights, strobes, and many more
 - FX³ & Standard Function Qualifiers** operate functions based on direction, Fo on or off, direction and Fo, and whether loco is moving.
 - Function Remapping** for custom function setup.
 - Master Light Switch** turns off all lights & functions with one keystroke.
 - Advanced Consist Function Controls**
- **Digitrax LocoMotion® System**-Your locomotives look like the real thing. The Digitrax LocoMotion System makes them run like the real thing, too!
 - Torque Compensation** for smooth as silk silent operation.
 - 128 Speed Step** operation (14 or 28 steps can also be used).
 - Momentum** with acceleration and deceleration.
 - Normal Direction of Travel** is user selectable.
 - Switching Speed** feature for easier and faster access to yard speeds.
 - 3 Step Speed Tables** set start, mid and max voltage for custom control.
 - 28 Step Speed Tables** with 256 level resolution for precise control.
- Program CVs using any Digitrax Compatible Control system without having to buy any extra equipment.
- Digitrax Easy Connect 9 Pin to DCC Medium Plug 1.0" harness
- Series 6 Decoder Features.
- Works with PX112-2 Power Xtender.
- Configurable FX³ Pulse Function available on all function outputs.
- 2 Digit and 4 Digit Addressing.
- Basic, Advanced & UniVersal Consisting.
- SuperSonic motor drive for silent operation.
- Direct mode programming.
- Decoder Reset CV with or without speed table reset.
- Transponder Equipped ready for transponding on your Layout.
- Motor Isolation Protection helps prevent damage to your decoder.
- DCC Compatible.
- FCC Part 15, Class B RFI compliant.
- Digitrax "No Worries" Warranty.

Parts List

1 DH126PS Function Decoder

1 Instruction Sheet

1 DHWHPS Digitrax Easy Connect 9 Pin to DCC Medium Plug 1.0" harness

Installation Information

See the Digitrax Decoder Manual for complete decoder test procedures, installation instructions, programming and technical information. Digitrax manuals and instructions are updated periodically. Please visit www.digitrax.com for the latest versions, technical updates and additional locomotive-specific installation instructions. **CAUTION: Programming and layout track must not exceed 16V when using this decoder.**

Installation Instructions

1. Carefully remove the locomotive's shell from the frame. Notice the orientation of the shell to the frame so that you can reinstall correctly.
2. The DH126PS uses the DHWHPS Digitrax Easy Connect 9 Pin Harness System which consists of a 1.0" harness that has a Digitrax 9-pin plug on one end and a DCC medium plug on the other. Remove the jumper plugs from the DCC medium socket on the factory light board and plug in the DCC plug end of the harness.
3. Plug the 9 Pin plug on the DHWHPS harness into the 9 Pin socket on the decoder. The plug is notched to fit easily into the socket in only one orientation.
4. Replace the loco shell. You are now ready to run your locomotive. The DH126PS is factory programmed to address 03. You can easily customize the address and other features. See section "Customizing Your Decoder" that follows.

Figure 1: DH126PS Wiring Diagram

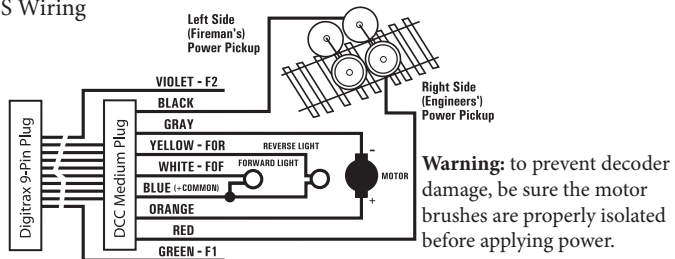

NOTE: The Violet and Green leads of the harness are not used by this decoder.

Installation Notes

1. Do not exceed the decoder's 500mA total function output rating.
2. To use a function output with an inductive (coil) type load, see the Digitrax Decoder Manual for more information to avoid damage to the decoder.
3. See the Digitrax Decoder Manual for full details of wiring 12-16V lamps, 1.5V lamps, and LEDs. Lamps that draw more than 80 mA when running require a 22 ohm 1/4 watt resistor in series with the directional light function lead to protect the decoder.

Customizing Your Decoder

Your Digitrax decoder is ready to run and will operate using address 03 with no additional programming. For a more prototypical railroading experience, your decoder can be customized for your specific locomotive by programming some of the Configuration Variables, or CVs, available. See the Digitrax Decoder Manual or the Digitrax web site for more information.

Changing the Decoder Address

The first CV most people change is the decoder address. This allows you to independently control each loco with a unique address. Digitrax decoders are shipped with CV01 (AD2), the two digit address, set to 03. Following is a brief description of how to change the decoder address with a Digitrax DT4xx series throttle. See your Starter Set Manual for complete programming instructions.

1. Place the loco on the **programming track not to exceed 16V**. Go into Program Mode on your system. On DT4xx throttle press **PROG**.
2. Choose AD2 for 2 digit addressing or AD4 for 4 digit addressing.
3. Choose the address you want to set up for the decoder.
4. Complete address programming by pressing **ENTER**.

Note: CV29 must also be programmed to enable 4 digit addressing, this is done automatically by the DT4xx throttles. See your Digitrax Decoder Manual or the Digitrax Toolbox App for how to set up CV29.

Decoder Reset CV08

Decoder reset lets you reset all CV values to the initial factory settings. To reset all CV values, program CV08 to a value of 008. You also have the option of resetting all the CV values except the 28 speed step tables and CV60 selected sound scheme. To do this program CV08 to a value of 009.

Warranty & Repair

Digitrax gives a one year “*No Worries*” *Warranty* against manufacturing defects and accidental customer damage on all Digitrax command stations, boosters, throttles, decoders, power supplies and layout control devices.

That’s it! A simple, straightforward warranty with no tricky language!

Visit www.digitrax.com for complete warranty details and instructions for returning items for repair.

Please return warranty items directly to Digitrax - DO NOT return items to place of purchase.



DH126PS
Fits Many HO Locomotives

Go Beyond DCC With Digitrax® Complete Train Control

Main Station

Starter Sets
LocoNet®
Power Supplies



Your Digitrax LocoNet® Starter Set is just the beginning of an exciting trip! Pick the one that's right for you!



LocoNet®
The Digitrax
Difference

Locomotive Shops

Mobile Decoders
Function Decoders
SoundFX™ Decoders

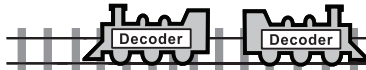

More Fun For Everyone

Add More Boosters, Advanced & Simple Throttles, Power Supplies, Universal Panels, IR and/or Radio for more trains and operators.

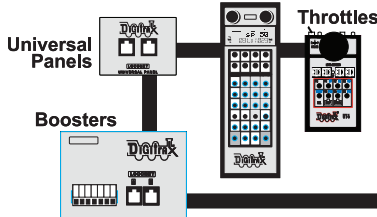

Maintenance Of Way

Make your layout more fun & simpler to operate!

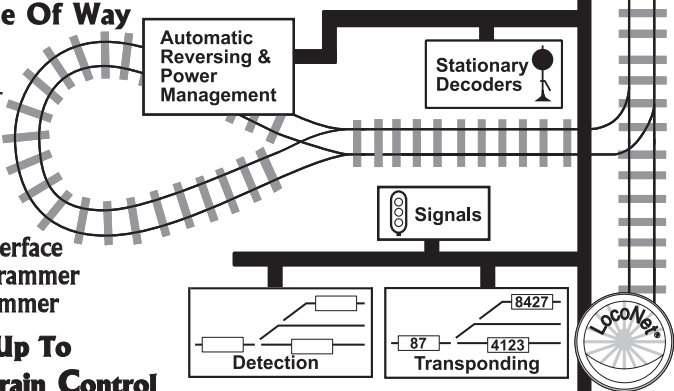

Computer Controls

Computer Interface
Decoder Programmer
Sound Programmer

It All Adds Up To Complete Train Control



Made in the USA



2443 Transmitter Road
Panama City, FL 32404

www.digitrax.com

Contact: www.digitrax.com/contact

Support: techsupport@digitrax.com

Repair: repair@digitrax.com

DH126PS

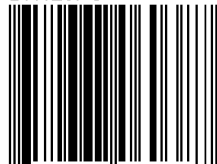

6 52667 06038 7