



Complete Train Control
Run Your Trains, Not Your Track!

TF4

All Scales

**DCC Quad Function
Decoder with Transponder**

**DCC Quad Function Decoder
with Transponder**

4x .125 Amp outputs .250 Amp Peak

Features:

- Four 125mA function outputs for lights or other functions (Peak rating is 250mA)
- Each function output can be operated independently
- Supports Both 2 Digit & 4 Digit Address Modes
- Programmable from DCC compatible equipment
- Configurable Strobe feature lets you simulate flashing lights on locos like FRED, Strobes, Mars Lights, etc. on yellow & white leads
- Programmable strobe effect & rate of lighting effects on yellow & white leads
- Standard on/off function operation on green & violet leads
- Integrated Digitrax DCC Transponder
- Can be used as a stand alone transponder or added to a unit that already has a non-transponding DCC decoder
- Compatible with Digitrax DCC Transponding Systems
- Can be used as a function only decoder with transponding enabled or disabled

Parts List

1 TF4 Decoder

1 Instruction sheet

Please Note: Some systems use hex notation and others use decimal notation. In this manual both values are given. The number preceded by the "x" is the hex number and the other number is the decimal value corresponding to the hex number. Simply use the correct notation for the system you are using. CV values shown as 2 digits are the same in hex & decimal



Made in U.S.A.



2443 Transmitter Road
Panama City, FL 32404
www.digitrax.com
T 850-872-9890
F 850-872-9557

TF4



6 52667 10008 3

307-1011-0000



Installation Information

A TF4 should not be connected to an existing transponder equipped DCC decoder unless the DCC decoder's transponder is disabled. This avoids having 2 transponders responding to the same address in the system.

Installation Instructions

Program the TF4's Address & Function Outputs

1. Before using your TF4, set its address. This may or may not be the same address as a mobile decoder already installed in the loco or car depending on how you are planning to use the TF4. In the case of TF4s being used as a stand alone transponder or as a function decoder, choose an address that is not the same as another mobile decoder address in use on the layout.
2. Connect the RED & BLACK wires of the TF4 to a service mode DCC programmer and program the TF4's address as you would any mobile decoder address. Follow the instructions for programming mobile decoders in your command station manual for the exact steps to use. The TF4 can be programmed with a 2 digit (Ad2/AD01/CV01) or 4 digit address (Ad4/CV17 & CV18). Remember to set CV29 to the appropriate value per your Decoder Manual for 2 digit or 4 digit operation. For 2 digit addressing CV29 is most commonly set to x06/006 decimal*. For 4 digit addressing, CV29 is most commonly set to x26/038 decimal*.
3. Set up which function numbers control the TF4's white, yellow, green & violet function leads. Program values for CV61 & CV64 per TABLE I.
4. Set up the configurable strobe effect for the TF4's function lead by programming a value between 00 & 07 into CV49 for the white lead and CV50 for the yellow lead. (See Table II). The green & violet lead can be used for standard on/off functions only.
5. Set up the rate of the effect by programming a value between 00 & 07 into CV62 for the white lead and CV63 for the yellow lead. See TABLE III.
6. When programming is complete, exit programming mode. Test for correct operation of the function after you install the TF4 in the locomotive.
7. Programming a TF4 after it is installed in tandem with a DCC decoder may yield unexpected results because of differences in the way various DCC decoders respond to programming. If you are not able to program your installed TF4, first try a different programming method. If this does not work, remove the TF4 and program it separately on the service mode track, then reinstall it in the loco.

Note: The TF4 does not use Operations Mode Programming.

TF4s are shipped with the two digit address (CV01) set at 03, CV61 set at 02 and CV64 set at 00 to enable transponding and use F1 for the white lead, F2 for the yellow lead, F3 for the green lead & F4 for the violet lead. CV49 & CV50 are set to a value of 00 for on/off function control for the white & yellow leads.

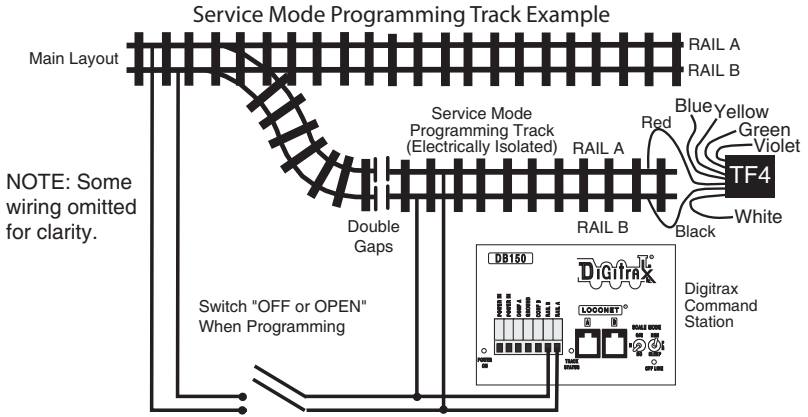

TABLE I: Function mapping for TF4's function outputs

CV64 Value	CV61 Value	White Lead	Yellow Lead	Green Lead	Violet Lead	TX
x00/000	x00/000	F1	F2	F3	F4	OFF
x00/000	x01/001	F0	F1	F2	F3	OFF
x00/000	x02/002	F1	F2	F3	F4	ON
x00/000	x03/003	F0	F1	F2	F3	ON
x01/001	x02/002	F3	F4	F5	F6	ON
x02/002	x02/002	F5	F6	F7	F8	ON
x03/003	x02/002	F9	F10	F11	F12	ON
x01/001	x00/000	F3	F4	F5	F6	OFF
x02/002	x00/000	F5	F6	F7	F8	OFF
x03/003	x00/000	F9	F10	F11	F12	OFF

Factory Default Value

Please refer to your Decoder Manual for additional information about CV61 & its uses.

TABLE II: CV49 (White Lead) & CV50 (Yellow Lead) CV Values for Configurable Strobe Effect Selection

CV Value	Configurable Strobe Effect
x00/000	Normal on/off
x01/001	Simulated FRED
x02/002	Simulated Mars
x03/003	Slow Strobe
x04/004	Single Pulse
x05/005	Double Pulse
x06/006	Medium Pulse
x07/007	Mostly on blinking off

Factory Default Value

TABLE III: CV62 (White Lead) & CV63 (Yellow Lead) Values for Setting Effect Rate

x00/000 (Slowest) to x07/007 (Fastest)

Install the TF4 in the Loco or Rolling Stock

1. Connect the TF4's RED and BLACK wires to the matching RED and BLACK track feed wires of an installed DCC mobile decoder.
2. If the TF4 is used by itself, for example in a caboose or box car without a DCC mobile decoder installed, connect the TF4's RED wire to the right hand track pickup and the TF4's BLACK wire to the left side track pickup.
3. No other parts are required to set up the transponder current pulses, since this is self-contained in the TF4.
4. Install the lamps using the TF4's blue, white, yellow, green & violet leads. The example below shows how to install two LEDs. Note that resistors must be installed as shown. Different resistor values can be used depending on how bright you want the LEDs to be. This is limited by the current ratings of the LEDs & the function lead being used.
5. Test for correct function operation using your DCC system.

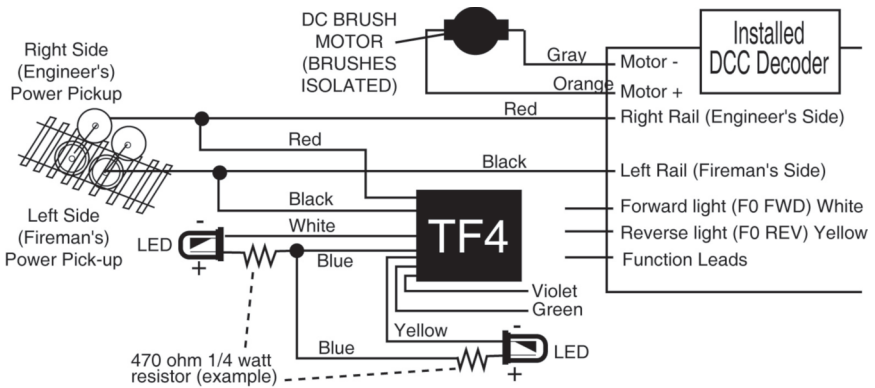

Test the installed TF4 for correct transponder operation

1. Place the unit with the installed TF4 on an empty transponding track section. This test assumes that the transponding track section is already set up, tested and is working before you start TF4 testing.
2. Using a DCC throttle, select the TF4 address that was programmed into the TF4 and verify that the transponder detector identifies the presence of the transponder device. Depending on how you have set up your transponding reporting to the system, your system should detect the presence of the address in that transponding section. For example, if you have an LT5 connected to the same BDL16 Zone plug as the track's Zone, you should show a blinking Zone power light that blinks when the TF4 equipped unit is placed on the empty transponding track section, and is steady when the TF4 is removed. This confirms correct installation and function of the TF4.
3. Another way to check the newly installed TF4's transponder address and location is to use any of the following:
 - a. The Find feature of a DT400 (See the DT400 or Super Chief Manual)
 - b. The transponder display of an attached PC with transponder capable software