



BDL162

LocoNet Occupancy Detector
For 16 Detection Sections

Features

- **Occupancy Detection** for 16 detection sections lets you know when rolling stock is in a detection section on your layout
- **Outputs for LEDs** to indicate local detection section occupancy and zone power status on a panel mount display
- **3 Amp capacity** per detection section
- **Connect to LocoNet** to transmit occupancy information to your LocoNet system
- **Detects any powered locomotive**
- **Detects un-powered rolling stock equipped with resistor wheel sets**
- **Plug and Play with Digitrax DCC**
- **Configurable for most DCC systems**
- **Automatically checks layout status** on power up of your system computer
- **Transponding** with addition of an RX4 Transponder Detector and transponders in your rolling stock provides additional capabilities:
 - **Identify** where specific rolling stock is on your layout
 - **Operations Mode Read Back** allows you to read CV values of decoders equipped with transponders

Parts List

1 BDL162	1 LT5 Tester
1 44-Pin Connector	1 Instruction Manual

The BDL162 requires a 12V-16V AC or DC power supply which is sold separately. Multiple BDL162s can be powered from the same power supply as long as 100mA is provided for each BDL162. One Digitrax PS12 power supply can run up to three BDL162s.

Digitrax Manuals and Instructions are updated periodically.
Please visit www.digitrax.com for the latest version of all manuals.

BDL162 LocoNet Occupancy Detector Manual

TABLE OF CONTENTS

1.0	Introduction	2
2.0	Terminology	2
3.0	Track Wiring for Detection with BDL162	4
3.1	Direct Home Wiring	4
3.2	Common Rail Wiring	7
4.0	BDL162 Installation Requirements	6
5.0	BDL162 Installation for Digitrax layouts	8
5.1	Direct Home Wiring	8
5.2	Common Rail Wiring	9
6.0	BDL162 Installation for Non-Digitrax Layouts.....	11
7.0	Customizing Your BDL162 -- Setting Up Option Switches	12
7.1	How to read back and change BDL162 Option Switches:	12
8.0	BDL162 Board Address	14
8.1	To set up the board address	14
9.0	Auto-Reversing	14
10.0	Power Management	16
11.0	Occupancy Indication	16
11.1	LocoNet Devices	16
11.2	LT5 Tester.....	17
11.3	Panel Indicator	16
12.0	Transponding with the BDL162	18
13.0	Troubleshooting: Checklist	18
13.1	Packet Reception	18
13.2	Mode Indication	18
11.3	Occupancy Debug	18
11.4	LocoNet Debug	19
11.5	Analog Locomotives	19
14.0	FCC Information	19
15.0	Warranty and Repair Information.....	20

Digitrax, LocoNet, Super Empire Builder, Super Chief, Zephyr and others included in this manual are trademarks of various manufacturers including Digitrax. U.S. & International Patents Pending for BDL162, RX4, transponding and other Digitrax products & technologies.

Digitrax, Inc. is not responsible for unintentional errors or omissions in this document.

1.0 Introduction

The BDL162 lets you know when a detection section on your layout is occupied. This occupancy detection capability is the first step toward prototypical control of your rolling stock, signaling, realistic surround sound effects and realistic modeling of your layout. Installing the BDL162 on your layout is easy and will make more prototypical operations possible.

The BDL162 uses digital signal processing (DSP) to give you occupancy detection for 4 zones, A through D, each with 4 detection sections, for a total of 16 detection sections. The number of BDL162s you use on your layout is determined by how many areas of track you want to monitor and how automated you want your layout to be--more detection sections require more BDL162s.

On your Digitrax system, the BDL162 reports detection section occupancy to the system via its LocoNet connection. This makes occupancy information available for use by any LocoNet device hooked up to LocoNet. For instance, the information can be used by the SE8/SE8c to set signals or by a computer program for dispatch control. A BDL162 can also host transponder detectors like the RX4 to let you implement Digitrax transponding for additional dispatcher control, surround sound or more layout automation.

On DCC systems without a Digitrax compatible LocoNet command station, a BDL162 can operate using only the RailSync DCC signal from any DCC system. In this case, the BDL162 can report detection information via a user-installed LED display panel.

2.0 Terminology

Following are some terms you might find useful as you work with the BDL162.

Direct home wiring is a layout wiring method where each power district and its booster is electrically isolated. The track within each power district uses a "common return" wiring method for occupancy detection and/or power management. Direct home wiring is the wiring method recommended by Digitrax for safety reasons & also because it makes detection work more prototypically.

Power district is the power wiring, track, components and equipment attached to that wiring, driven by a single properly isolated booster. The track for a power district is double gapped on both ends of the district. The BDL162 is used to set up detection sections within one or more power districts.

Power sub-district is the wiring, components and equipment that are controlled from both power bus wires by their own power management device, for example a reversing section controlled by an automated reversing device like the PM42. Power sub-districts are gapped on both ends.

Detection common is the common return used within a properly electrically isolated power district for implementing occupancy detection.

Security element is the plant, including track, associated with any reporting,

interlocking and/or signaling for that track section.

Whole layout common rail is a method of wiring layouts where power districts and their boosters are connected electrically by a common rail or common power bus return wire. This method is traditionally used for conventionally controlled layouts. The track feeds for one rail are connected together to one output of the power pack. The other rail is gapped and the track feeds are connected to the power pack through block control switches. Whole layout common rail wiring has a disadvantage when it comes to detection systems because detectors are not able to independently monitor whether zone power is on or off. There is no way to tell whether occupancy detection is actually working in any given detection section.

Detection Section is a section of track gapped on one or both rails and connected to an occupancy detector so that the detector can sense the presence of a loco (or other specially equipped cars) in that section of track.

Occupancy detector is a device that senses the presence of a locomotive (or specially equipped cars) in a section of track that is set up for occupancy detection. Occupancy detectors also provide feedback to indicate occupancy. This feedback may be in the form of a lamp on a control panel or it may be a feedback message sent to the system that can be used by other layout devices. Also called a block occupancy detector on conventional layouts. Detectors are not covered by the DCC Standards or Recommended Practices.

Transponder is an electronic device that is installed in rolling stock and can be assigned a unique address. Transponders provide information to transponder detectors installed on the layout. This lets the system determine in which detection section the transponder is currently located. Transponders are included in many Digitrax premium decoders. TD1 (transponder) & TL1 (transponder with light output) are available as separate units that can be added to locos with existing decoders or to other rolling stock without decoders if you want to use them for transponding only and don't need motor control.

Transponder detector is an electronic device installed in a detection section on the layout that receives the information broadcast from a transponder. The transponder detector sends feedback to the system to let it determine the detection section location of any given transponder at any time. RX4 Transponder detectors are hosted by the BDL162 and upgrade 4 detection zones of the BDL162 to be transponder detection zones. In this case, each transponding zone encompasses 4 detection zones.

The BDL162 is divided into four **zones**. Each zone supports 4 detection sections and each zone can be run from a different booster.

3.0 Track Wiring for Detection with the BDL162

The key to proper wiring for occupancy detection is planning. Your layout will be divided into detection sections that can range anywhere from several inches to several feet in length. This process is somewhat subjective, with the number and length of a detection sections varying depending on your layout, train length and the purpose of the detection.

It is best to plan your detection sections based upon the operations you want to accomplish on your layout before cutting gaps in the track and installing the BDL162. For instance, a grade level signal crossing may require from two to four different detection sections in order to create the effects you want with the lights and gates operating for trains traveling in either direction. Signal lights will require information from two detection sections in front of the signal in order to function like the prototype. Detection is not only useful but critical if operating a hidden staging area--occupancy detection will let you know which tracks are occupied in hidden staging areas. In your initial wiring installation, not all sections have to be connected to BDL162s; they can be connected to a terminal strip and then to boosters or power management devices. Additional BDL162s can then be inserted later as needed to further develop your layout.

Additional information about planning and installing the BDL162 can be found on the web site in the document: *Advanced Transponding Application Note* within the Digitrax Application Notes and Technical Information section of the site. The form, *BDL162 Planning Worksheet*, is also available in the same section for documenting your setup for future reference and trouble shooting.

Whether you are building a new layout or installing your BDL162 on an existing system, there are two basic wiring formats: direct home wiring and whole layout common wiring.

3.1 Direct Home Layout Wiring

Digitrax strongly recommends direct home wiring where each power district and its booster are electrically isolated. This method of wiring has safety advantages and makes troubleshooting problems easier. In addition, direct home wiring makes detection work more prototypically.

With direct home wiring, the BDL162 can determine and indicate whether any of its 4 zones is powered or not (possibly short-circuited) even when there is nothing on the rails in the detection sections. The BDL162 factory set logic causes the detection sections to show "occupied" if the associated zone's power is off (because in this case, detection is not possible). This factory setup matches typical prototype detection safety practices. **Figure 1** shows an example of a direct home wiring layout with a single power district with multiple detection sections. zone A with 4 detection sections (1-4) and zone D with one detection section (16) has been wired wired in this example.

Figure 1: Direct Home Wiring Example

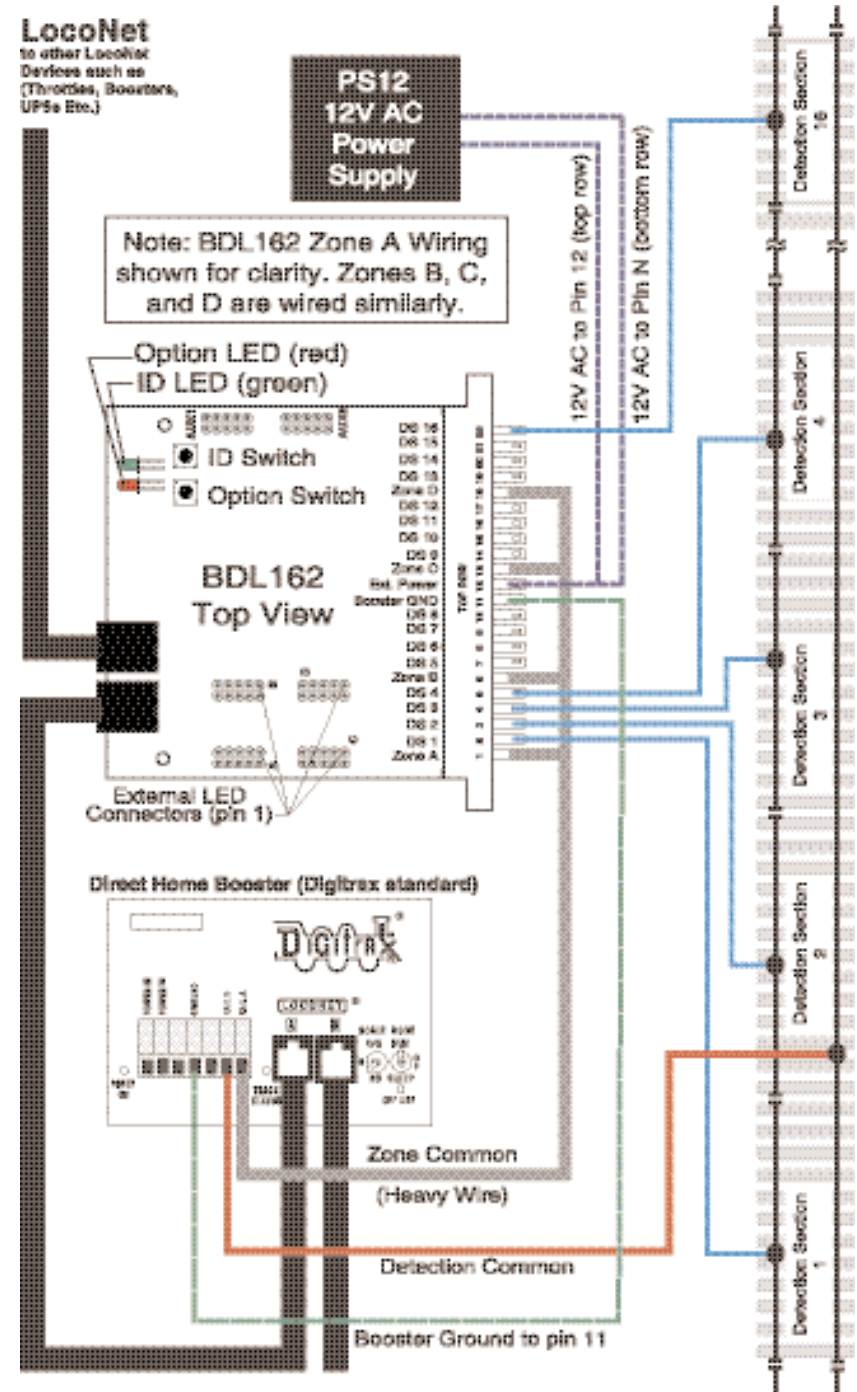
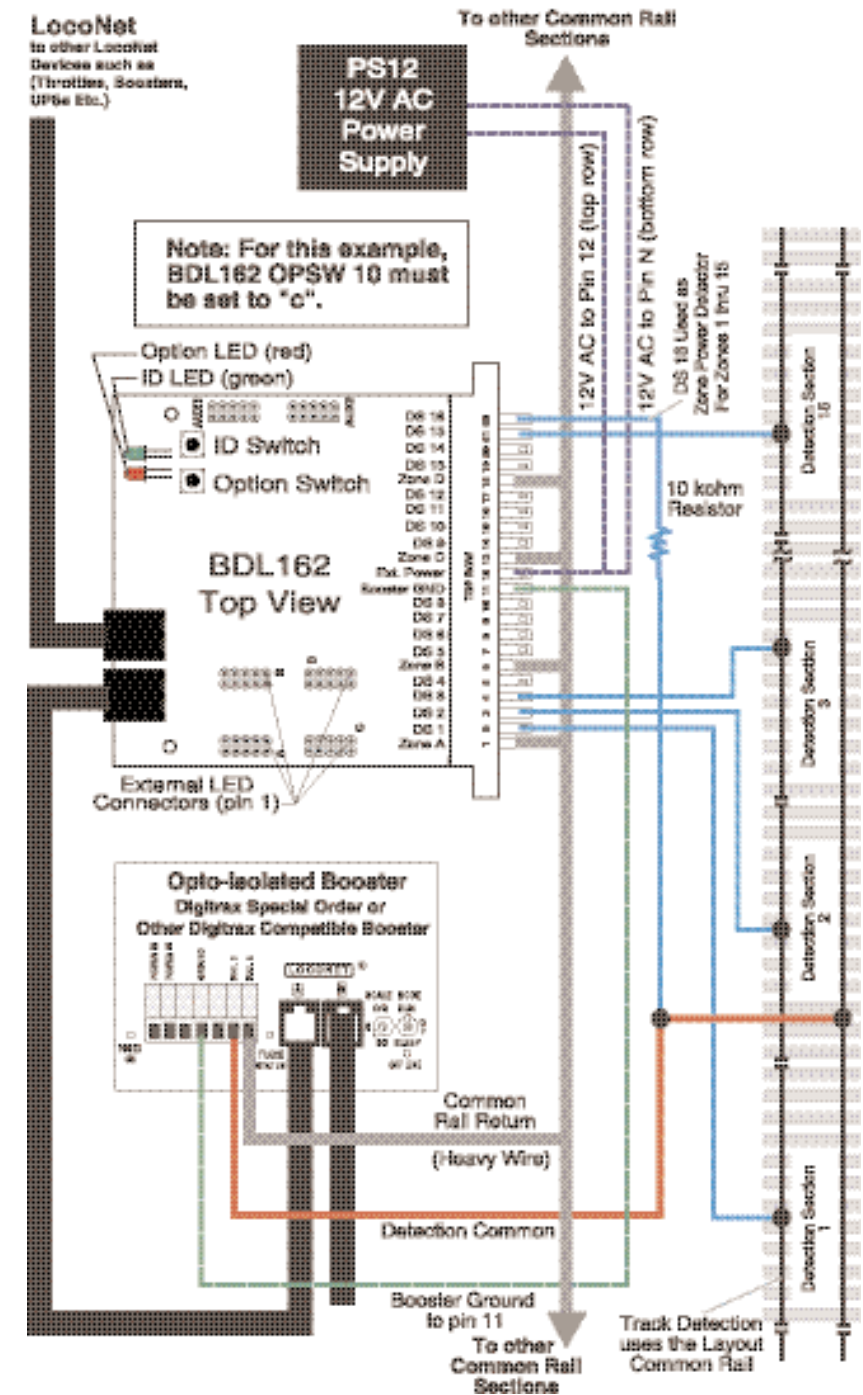

Figure 2: Whole Layout Common Rail Wiring Example



3.2 Common Rail Wiring

Whole layout common rail is a method of wiring layouts where power districts and their boosters are electrically connected using a common rail or common power bus return wire. Whole layout common rail wiring is a disadvantage when it comes to detection systems since detectors cannot independently monitor whether zone power is on or off so they can't tell whether occupancy detection is working in any given detection section. See **Figure 2: Whole Layout Common Rail Wiring** for an example of wiring a single power district and one zone with four detection sections.

4.0 BDL162 Installation Requirements

The BDL162 wiring panels should be located near the highest feeder density in order to minimize the lengths of wires feeding from the track to the BDL162. Planning the detection sections on the layout and the associated wiring on the wiring panel is covered in more detail in the technical applications paper, Advanced Transponding Application Note, available at www.digitrax.com. The paper includes photographs of a sample installation of the BDL162 with associated PM42 and RX4. **Figure 3** shows suggested minimum space requirements for installing a single BDL162 and the optional RX4 Transponding Detector on a wiring panel. See the RX4 manual for more information. Allow space on your mounting panel for the terminal strip, additional BDL162s and any PM42s required for power management.

1. Drill mounting holes in the end of the 44-pin connector (**Figure 3**) or mount using existing holes and right angle brackets.
2. Screw the connector directly to the wiring panel board.

Figure 3: BDL162 Installation Space

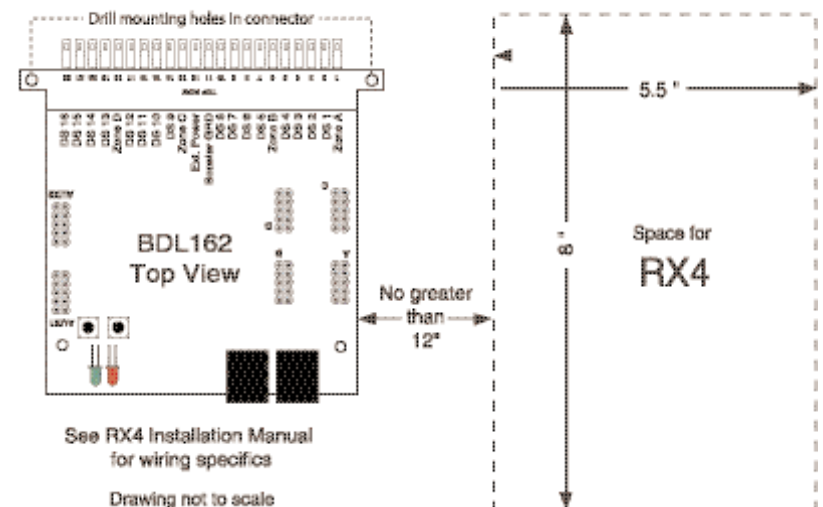

5.0 BDL162 Installation for Digitrax Systems

5.1 Wiring the BDL162 for a Digitrax Direct Home Wiring Layout

1. After mounting the 44-pin connector to the board (see section 4.0), label the top of the 44-pin connector for easy identification of the wires, using zone letters (A,B,C,D) and detection section numbers (1-16) (See *Figure 1*). Note, these are not the same as the pin identification numbers that are already molded on the connector.
Hint: Some users assign each BDL162 board a letter designation to use with the detection section number for tracking outputs. For example the first BDL162 board would be “A” and the detection sections connected to it would be labeled “A1”, “A2”...“A16” on the wiring panel terminal strip, on the rough layout and on the layout diagram for easier troubleshooting.
2. Solder one wire (AC1) from a 12-16V AC or DC power supply to the pin 12 and the second wire (AC2) from the power supply to the pin N on the BDL162's 44-pin connector. This powers the BDL162. Multiple BDL162 units can be supplied by a single shared supply as long as you provide at least 100mA for each BDL162. This power supply should not power any devices other than BDL162s.
3. Solder the ground wire from the Digitrax booster ground or common (case) to pin 11 of the 44-pin connector. Nothing is connected to pin M.
4. The end of the wire from each zone common and detection section should be stripped approximately 1/4” and inserted through the holes in each pin pair on the connector as indicated in *Table 1 and Figure 4*. Solder the wire to each pin. The zone common connections to the booster should be as short as possible and relatively heavy gauge, since they are common to all four detectors in the zone. For example, a 12AWG zone connection to the booster should be less than 10 feet for best performance.
5. Plug the BDL162 board firmly into the 44-pin connector.
6. Connect a LocoNet cable into one of the BDL162's LocoNet jacks.
7. Apply power to the unit. The red and green LEDs will light up as power is applied to the unit. The red LED will go out and the green LED will stay on and “wink” off once, approximately every 2 seconds, indicating that it is connected to LocoNet and seeing DCC packets.

The BDL162's option switches are factory set at the values that will work for most direct home wired layouts. You can fine-tune the BDL162's characteristics using its option switches which can be set using a Digitrax compatible throttle or a PC with LocoNet compatible software that can control turnouts. See Section 7: *"Customizing your BDL162 By Setting Up Option Switches."*

5.2 Wiring the BDL162 for Whole Layout Common Rail Wiring

Whole layout common rail wiring cannot independently monitor whether zone power is on or off so it can't tell whether occupancy detection is working or not in any given detection section. The BDL162 can be easily configured to overcome this disadvantage by using detection section 16 to monitor track power-- if track power is on in section 16 then detection is working in sections 1-15.

1. After mounting the 44-pin connector to the board (see section 4.0), label the connector Using the zones and detection section numbers for easy identification of the pins when wiring. (See hint on labeling for wire tracing and troubleshooting under 5.1.1 wiring for direct home wiring systems.)
2. Solder one wire (AC1) from a 12-16V AC or DC power supply to the pin 12 and the second wire (AC2) from the power supply to the pin N on the BDL162's 44-pin connector. This powers the BDL162. Multiple BDL162 units can be supplied by a single shared supply as long as you provide at least 100mA for each BDL162. This power supply should not power any devices other than BDL162s.
3. Solder the ground wire from the Digitrax booster ground or common (case) to pin 11 of the 44-pin connector. Nothing is connected to pin M.
4. The end of the wire from each detection section and zone common should be stripped approximately 1/4” and inserted through the holes in each pin pair on the connector as indicated in *Table 1 and Figure 4*. Solder the wire to each pin. The zone common connections to the booster should be as short as possible and relatively heavy gauge, since they are common to all four detectors in the zone. For example, a 12AWG zone connection to the booster should be less than 10 feet for best performance.
5. Wire a 10K resistor from detection section 16 (pin 22) to the detection common return for the whole BDL162 (*Figure 2*). Detection section 16 will be active when the BDL162 sees track power and you will be able to tell whether detection is actually available in detection sections 1 through 15.
6. Plug the BDL162 board firmly into the 44-pin connector.
7. Connect LocoNet via one of the BDL162's LocoNet jacks.
8. The first time you apply power to the unit, hold down the switch located behind the red LED on the BDL162 to set it up for whole layout common rail operation. The red and green LEDs will light up as power is applied to the unit. The red LED will go out and the green LED will stay on and “wink” off twice, approximately every 2 seconds, indicating that it is set up for common rail wiring and that it is connected to LocoNet and seeing DCC packets.

The BDL162's option switch 10 is set to “c” (closed) to allow detection section 16 to be used to monitor zone power on a whole layout common rail wired system. You can fine-tune the BDL162's characteristics using its option switches which can be set using a Digitrax compatible throttle or a PC with LocoNet compatible software that can control turnouts. See Section 7: *"Customizing your BDL162 By Setting Up Option Switches."*

Table 1: BDL162 44-Pin Connector Pin Out Configuration

Top Pin	Bottom Pin	Name	Connect To
1	A	Zone A	Connection to booster for Zone A
2	B	DS 1	Isolated track section for Detection Section 1
3	C	DS 2	Isolated track section for Detection Section 2
4	D	DS 3	Isolated track section for Detection Section 3
5	E	DS 4	Isolated track section for Detection Section 4
6	F	Zone B	Connection to booster for Zone B
7	H	DS 5	Isolated track section for Detection Section 5
8	J	DS 6	Isolated track section for Detection Section 6
9	K	DS 7	Isolated track section for Detection Section 7
10	L	DS 8	Isolated track section for Detection Section 8
11		Ground**	LocoNet/BDL162 ground to Booster case/common ground
	M		Nothing attached to this pin
12		AC Power 1*	Power input to BDL162 : AC 12V to 15V, or +DC 12V to 15V
	N	AC Power 2*	Power input to BDL162 : AC 12V to 15V, or +DC 12V to 15V
13	P	Zone C	Connection to booster for Zone C
14	R	DS 9	Isolated track section for Detection Section 9
15	S	DS 10	Isolated track section for Detection Section 10
16	T	DS 11	Isolated track section for Detection Section 11
17	U	DS 12	Isolated track section for Detection Section 12
18	V	Zone D	Connection to booster for Zone D
19	W	DS 13	Isolated track section for Detection Section 13
20	X	DS 14	Isolated track section for Detection Section 14
21	Y	DS 15	Isolated track section for Detection Section 15
22	Z	DS 16	Isolated track section for Detection Section 16

Notes:

- 1) All connector pins are paired top (component side) and bottom (solder side) except 11/M and 12/N. For 6 Amp current rating with 3 Amp connector pins, track/zone wires **must** be connected to both pin pairs: e.g. Zone A = pins 1 & A (See Figure 4).
- 2) Letters G, I, O & Q are not used as pin designations on the connector.
- 3) Power connections should be made to a power supply dedicated to BDL162 use only. Multiple BDL162 units can be supplied by a single shared supply as long as you provide at least 100mA for each BDL162.
- 4) The Ground connection, pin 11, must be made to the booster for correct BDL162 operation.

Figure 4: Connecting Zone & Detection Section Wires to the 44-Pin Connector.

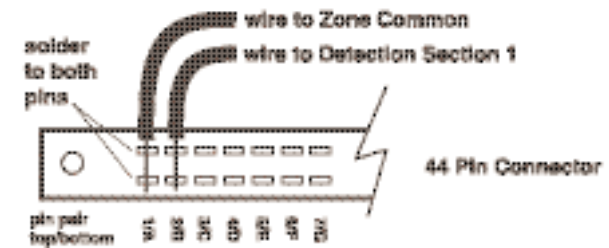

6.0 BDL162 Installation for non Digitrax Layouts

To make set up simpler and easier for non-Digitrax layouts to use the BDL162, there are two quick configuration buttons that let you set up your unit to work with either direct home or whole layout common rail without using a Digitrax throttle or computer.

1. If you are using direct home wiring, use Section 5.1 as an example for wiring detection sections. If you are using whole layout common rail wiring, use Section 5.2 as an example for wiring detection sections.
2. Connect the left-most pin of the RJ12 socket (the RailSync pin) to Rail A output of your system. The source of the DCC signal must match the DCC signal being sent by the booster to the detection sections handled by the BDL162. It is best that this signal stays active even when the booster output is shorted or disconnected from the BDL162 zone inputs, for example by a PM42 Power Manager.
3. Configure the BDL162 for your wiring system
 - a) For direct home wiring layouts, the “ID” switch behind the green ID LED is held down when AC power is first applied, the BDL162 will operate on direct home layouts (the factory setting). When DCC packets are supplied to the RailSync pin of the RJ12 connector the ID LED will be lit and “wink” off once every 2 seconds to indicate direct home operation is selected.
 - b) When operating on a whole layout common rail system, the “OPTION” switch behind the red option LED is held down when AC power is first applied to the BDL162. When DCC packets are supplied to the RailSync pin connector the ID LED will be lit and “wink” off twice every 2 seconds to indicate whole layout common rail operation is selected.

Note: If either switch is pressed when the BDL162 is first powered up, the BDL162 will be re-configured.

7.0 Customizing Your BDL162 -- Setting Up Option Switches

The option switches and settings you can use to customize your BDL162 are indicated in **Table 2**. These option switches are set up using your Digitrax throttle's SWITCH commands. SWITCH mode is normally used for operating turnouts by issuing closed ("c") or thrown ("t") commands. In the case of your BDL162, each switch address is a BDL162 option switch.

7.1 How to read back and change BDL162 Option Switches (OpSw):

1. Power up your BDL162 and connect it to LocoNet.
2. Connect a DT or UT series Digitrax throttle to one of the the BDL162's LocoNet connectors.
3. Press the switch behind the red option LED for about 1 second, then release it. The red option and green ID LEDs will flash alternately to let you know that you are in option switch setup mode.
4. Go into SWITCH mode on your throttle. Dial up the switch number that corresponds to the OpSw you want to change and issue a closed "c" or thrown "t" command to set the OpSw to the desired setting. The OpSw is changed as soon as you issue the SWITCH command. See below for instructions for specific Digitrax throttles.
5. When BDL162 OpSws are set up as desired, press the switch behind the red option LED for about 1 second and release it, the BDL162 will exit option switch set up mode. You can also exit option switch set up mode by turning off the power to the BDL162 and then turning it back on.

DT100, DT200 or DT300 series throttle, press **MODE/DISP** key on the throttle to enter SWITCH mode. Use the throttle to read back each OpSw in **Table 2** by dialing it up on the throttle and looking at its setting ("c" or "t") in the display. If you need to make a change to the OpSw simply press the **c** or **t** key to make the change you want. Once you are finished reading back and changing settings, simply wait 6 seconds for the throttle to time out and return to "LOCO" mode. Be sure to complete step 5 above when finished setting OpSws.

UT series throttle, press the **RUN/STOP** and **DISP/OPSW** keys at the same time to enter SWITCH mode. With a UT throttle, you won't be able to read back the BDL162 OpSw settings but you can change them by dialing up the OpSw number you want to modify and pressing the **c** key. When the LED under the **c** key is on, the OpSw is set to closed; when it is off, the OpSw is set to thrown (the factory setting). When you are finished setting up BDL162 OpSws, return to LOCO mode by pressing **RUN/STOP** and **DISP/OPSW** keys at the same time. Be sure to complete step 5 above when finished setting OpSws.

DT400 series throttle, press **SWCH** key to enter into the switch mode. Use the keyboard to enter the OpSw number and view the current setting for the OpSw you want to change ("t" or "c" in the display). Press the **t** or **c** key to change the setting. To return to "LOCO" mode press the **EXIT** key.

Table 2: BDL162 Option Switches (OpSw)

The following table shows what each OpSw is used for when it is set for thrown or closed. Factory settings are indicated by shaded boxes.

OPSW	t = thrown	c = closed
01	Set up for operation with direct home wired layouts (Digitrax recommended wiring)	Set up for whole layout common rail wired layouts
05	Disable Transponding	Enable Transponding
09	Detection sections show occupied when zone power is off	No forced occupied detection when zone power is off
10	Use detection section 16 as a normal detection section.	Use detection section 16 as zone power ON qualifier for whole layout common rail wiring
11	Allow this BDL162 to be the master.	Do not allow this BDL162 to be master
12	Allow this BDL162 to terminate LocoNet	Do not allow this BDL126 to terminate LocoNet
13	Power up delay 5 seconds for DB150 compatibility	Power up delay 1/2 second
19	Use regular threshold sense DCC occupancy. (approx 22 Kohms minimum)	Use high threshold sense DCC occupancy (approx 10 Kohms minimum)
25	16 LEDs show occupancy	Drive 16 occupancy LEDs from SWITCH commands (not occupancy)
26	Occupancy LEDs decoded from track DCC switch commands	Occupancy LEDs decoded from LocoNet SWITCH commands
40	Direct home wiring compatible	Make all option switches factory settings

NOTE: If a turnout switch number on the layout matches the OpSw number being set during this process, the turnout will be activated during the OpSw setting. Once the BDL162 OpSw configuration is completed and you have exited option switch setup mode (See section 7.1, Step 5), simply reset the turnout to the desired position. This will have no affect on the OpSw settings of your BDL162.

8.0 BDL162 Board Address

When the BDL162 is connected to LocoNet, it will communicate coded detection information to the system. If you wish to report BDL162 status to LocoNet and attached devices or computers that can interpret these messages, you will probably want to set up a unique board address for each BDL162. Board addresses can range from 01 to 999. It is recommended that you make a record of the addresses you use for all devices connected to your layout.

8.1 To set up the BDL162 board address

1. Power up your BDL162.
2. Press the switch behind the green ID LED for about 1 second, then release it. The green ID LED will blink. The red option LED will not light. This let's you know that you are in board address set up mode.
3. Connect a DT or UT series Digitrax throttle to the BDL162's LocoNet connector.
4. Go into SWITCH mode on the throttle. Select the switch number that corresponds to the board address you want to set and issue a closed "c" command to set the board address. The board address is changed as soon as you issue the SWITCH command. See following instructions for using specific Digitrax throttles for setting the address.

DT100, DT200 or DT300 series throttle, press the **MODE/DISP** key on the throttle to enter SWITCH mode. Use the throttle to dial up the board address you would like to assign to the BDL162. When the address is in the display, press the **c** key to issue a closed command. This will set the board address for the BDL162. The green LED will then go steady green to indicate BDL162 Power on.

UT series throttle, press the **RUN/STOP** and **DISP/OPSW** keys at the same time to enter SWITCH mode. With a UT throttle, dial up the board address you would like to assign to the BDL162. Press the **c** key until the corresponding LED is lit. This will set the board address for the BDL162. The green LED will then go steady green to indicate BDL162 Power ON. When you are finished setting up BDL162's board address, return to LOCO mode by pressing the **RUN/STOP** and **DISP/OPSW** keys at the same time to exit SWITCH mode.

DT400 series throttle, press **SWCH** key to enter into the switch mode. Use the keyboard to enter the board address number you want to set. Press the **c** key to set the address. To return to "LOCO" mode press the **EXIT** key or the **LOCO** key twice.

9.0 Auto-Reversing

Note that an auto-reverse section can only use detection sections that are contained in a BDL162 zone that is correctly set up for auto-reversing. See

Figure 5: Reversing Section Wiring for a wiring example.

Figure 5: Reversing Section Wiring Example

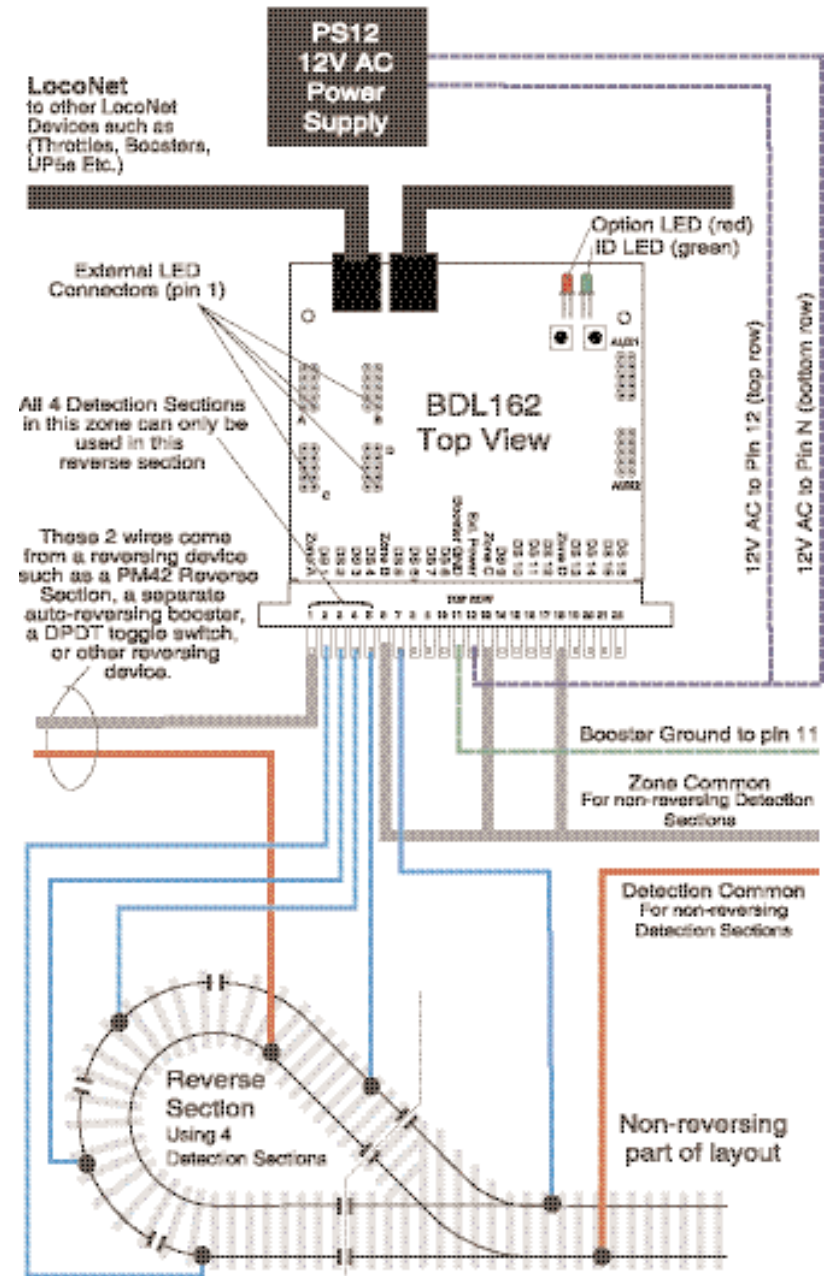

10.0 Power Management

The BDL162 is designed to operate “downstream” of the Digitrax boosters and power management devices. The BDL162 is the "last" device in the chain from booster to power manager to BDL162. It is connected directly to the track detection section. **There should be no other connections to any detection section that will draw track power or the detection section will always show occupied.**

If a device is used to switch off power feeding the BDL162 and the track it is connected to, for example, a PM42 Power Manager, it should break the track power to both the zone and detection common rail. If a device only switches off a single leg, then it must be placed in the detection common rail wiring.

11.0 Occupancy Indication

The BDL162 can report occupancy information via the LocoNet connection or via direct output to a user created LED panel.

11.1 LocoNet Devices

The BDL162 provides occupancy messages to LocoNet that can be used by computer software for a visual display of occupancy status on the layout or to other devices on the layout. For instance, the Digitrax SE8 or SE8c can use these messages to control signals on the layout. See the operations manual of your computer software or the SE8C for details on installation and operation.

11.2 LT5 Tester

Each BDL162 comes with an LT5 that will help you with layout wiring and troubleshooting for transponding & detection. The LT5 plugs onto the LED connections of BDL162 and the LEDs on the LT5 light when detection sections are occupied. The status of power to each zone is also shown. (Figure 6.)

Figure 6: LT5 Tester

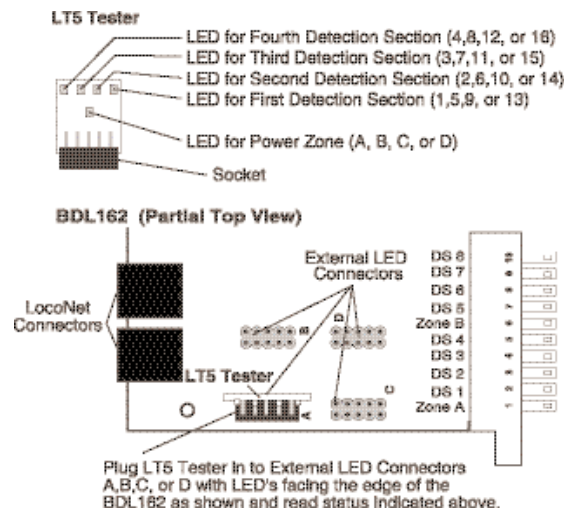

11.3 Panel Indicator Wiring

You can build a display panel with a track schematic and LEDs to indicate track occupancy by connecting LEDs to the output connectors A, B, C, and D shown in Figure 6. For a panel display of occupancy status made up with user supplied LEDs, connect to the four 0.1" 2x5 headers, and wire up LEDs as shown in Figure 7: LED Panel Indicators Wiring. DigiKey (1-800-DigiKey) part number M1AXA-1036R-ND is a convenient plug and cable assembly that you can use to wire LED indicators. Header “A” includes the 4 detection indicators for detection sections 1 to 4 and the zone power indicator for zone A that includes these four detection sections

The BDL162 incorporates current setting resistors to set the LED current typically about 3mA. If you use higher LED drive currents you can use external transistors etc to amplify the LED current.

The LED drive from the BDL162 is active high at about +5 volts above the BDL162 ground pin, via a 1 Kohm resistor. Note that the ribbon cable includes separate ground return conductors for each LED that allow a 10 conductor ribbon cable to be split into 5 pairs to conveniently route to individual LEDs. Be sure to connect the +ve active output leads to the LED anodes.

Figure 7: LED Display Wiring

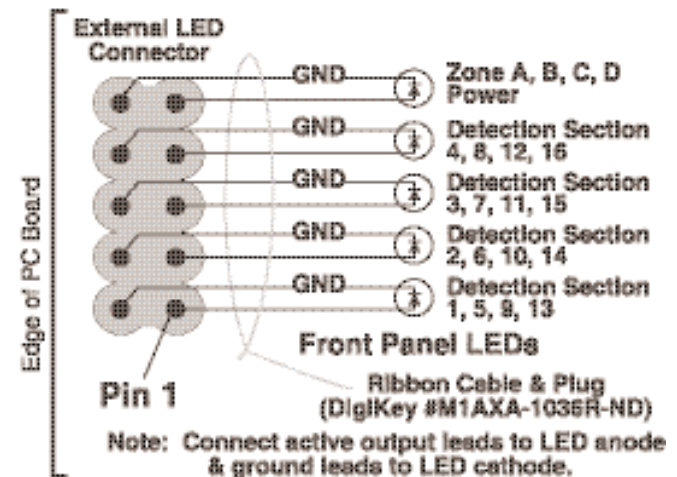

12.0 Transponding with the BDL162

The BDL162 is ready to set up four transponding zones with the addition of an RX4 Transponder Detector. Transponding allows two-way communication with rolling stock equipped with a transponding decoder or a stand alone transponder. Many of the Digitrax Premium and FX³ decoders are transponder-equipped. You may need to set the decoder CV61 value to enable transponding. The set up for transponding operation is covered in the RX4 Installation Manual and in the Digitrax Decoder Manual.

Transponding allows you to keep track of where individual transponder-equipped rolling stock is located on your layout. Your dispatcher can keep better track of trains, knowing exactly where each train is located. Additional applications include surround sound specific for *each* loco, automated train control, and remote layout operation. Transponding also allows Operations Mode Read Back of decoder CVs while operating your trains on your layout providing you additional control over your locomotives.

If you are planning to use Digitrax Transponding with your BDL162 please allow space to install the RX4 Transponder Receiver as shown in *Figure 3*. Additional information about transponding can be found in the RX4 instruction manual and on the web in the Digitrax Application Notes and Technical Information Section/*Advanced Transponding Application Note*.

13.0 Troubleshooting: Checklist

13.1 Packet Reception

Be sure the green ID LED is ON & is “winking” off about every 2 seconds. This means that correctly formatted DCC packets are being decoded from the left most (Railsync) pin of the RJ12 LocoNet socket. For DCC detection, the same DCC packet signal that drives the booster must be connected to the RJ12 socket's left most pin. If you are using LocoNet and you do not see the green LED blinking pattern described, check to be sure that the system is powered up and your LocoNet cable connections are good. You can use your LT-1 to test the LocoNet cables if you suspect there is a problem with them. If the green LED on the BDL162 is not lit, check the external power connections.

13.2 Mode Indication

The winking on the green ID LED indicates the primary BDL162 mode. A single wink indicates standard Digitrax compatible Direct Home track wiring and detection logic will be used, a double wink indicates Common Rail wiring and detection logic is to be used. For Common Rail, all 4 BDL162 zone connections must be made to the System Common ground point. Be sure the BDL162 configuration is appropriate for your usage.

13.3 Occupancy Debug

Use the LT5 provided with your BDL162 as described in Section 11.2. You can also build a simple LED display debugger as follows. Use a 10 pin plug and cable such as DigiKey (1-800-DigiKey) part number M1AXA-1036R-ND that

will plug into one of the 4 occupancy LED headers on the BDL162 and solder LEDs to the wires to create an array of LEDs (see *Figure 6*). By plugging this display array into one of the 4 occupancy LED headers (*Figure 5*, marked A,B,C & D), you can see the state of the zone and occupancies for that header. This allows you to easily check the zone sensitivity (typically 22 Kohms to give detection). This also aids in the determination of detection number and activity for a track detection section. Many detection problems are related to wiring problems or poor connections to the detection section rather than to the actual BDL162. By using the display array, you can eliminate the wiring issues from the equation and be sure that the BDL162 is set up correctly.

Remember, if the zone power is OFF, the occupancy LEDs should be set up so that they will be on to be sure that signaling systems or a CTC/dispatcher will see the detection section in its most restricted aspect.

13.4 LocoNet Debug

If you are using LocoNet for reporting, be sure that the configuration is correct for your usage. In normal operations the red “option” LED will blink ON briefly when valid LocoNet messages are seen confirming a good LocoNet network connection.

13.5 Analog Locomotives

The motor inductance of analog locomotives may in some installations cause cross talk among the BDL162 detection sections. The addition of a 220ohm, 3 watt, wire wound resistor between the booster track terminals (Rail A and Rail B on Digitrax boosters) will typically reduce the effect of this cross talk. Simply use a leaded resistor as a jumper between the booster's two track terminals.

14.0 FCC Information

Radio or TV Interference: (this information is MANDATED by the FCC) This equipment has been tested and found to comply with the limits for a Class B digital device, pursuant to part 15 of the FCC rules. These limits are designed to provide reasonable protection against harmful interference when the equipment is operated in a residential environment. This equipment generates, uses and can radiate radio frequency energy and, if not installed and used in accordance with the instruction manual, may cause harmful interference to radio communications. However, there is no guarantee that interference will not occur in a particular installation. If this equipment does cause harmful interference to radio or television reception, which can be determined by turning the equipment off and on, the user is encouraged to try to correct the interference by one or more of the following measures:

- Reorient or relocate the receiving antenna.
- Increase the separation between the equipment and the receiver.

-
-
- Connect the equipment into an outlet on a circuit different from that to which the receiver is connected.
 - Consult the dealer or an experienced radio/TV technician for help.

Note: Any modifications to the equipment not expressly approved by Digitrax voids the user's authority to operate under and be in compliance with CFR 47 rules, as administered by the Federal Communication Commission. Digitrax believes any conscientiously installed equipment following guidelines in this manual would be unlikely to experience RFI problems.

15.0 Warranty and Repair Information

Digitrax guarantees the BDL162 to be free from manufacturing defects for five years from the date of purchase. These units are not user serviceable. If a defect occurs, return the unit to Digitrax for service. Digitrax will repair or replace BDL162s at our discretion at no charge to you for five years from purchase date. This warranty excludes damage due to abuse, such as failure to properly protect against input over current with a fuse or circuit breaker or applying excessive input voltage to the unit.

Digitrax will make non-warranty repairs needed because of physical damage or electrical abuse at fair and reasonable rates.

All warranties on Digitrax products are limited to refund of purchase price or repair or replacement of Digitrax products at the sole discretion of Digitrax.

In the event that Digitrax products are not installed or used in accordance with the manufacturer's specifications, any and all warranties either expressed or implied are void. Except to the extent expressly stated in this section, there are no warranties, express or implied, including but not limited to any warranties of merchantability or fitness for a particular purpose.

Digitrax, Inc. reserves the right to make changes in design and specifications and/or to make additions or improvements in its products without imposing any obligations upon itself to install these changes, additions or improvements on products previously manufactured.



BDL162

LocoNet Occupancy Detector

Movin' Down The Tracks With **DIGITRAX** Digitrax Command Control

Main Station

Starter Sets
LocoNet
Power Supplies

RADIO
EQUIPPED
Available

Your Digitrax LocoNet® Starter Set is just the beginning of an exciting trip!

Pick the one that's right for you!



Locomotive Shops

Mobile Decoders
Function Decoders



More Fun For Everyone

Add More Boosters, Advanced & Simple Throttles, Universal Panels, IR and/or Radio for more trains and operators.

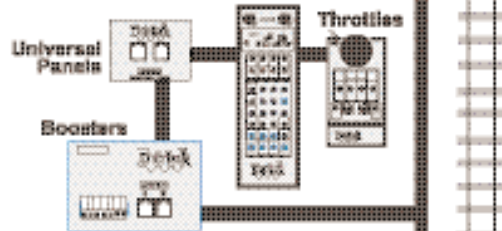

Maintenance Of Way

Make your layout more fun & simpler to operate!

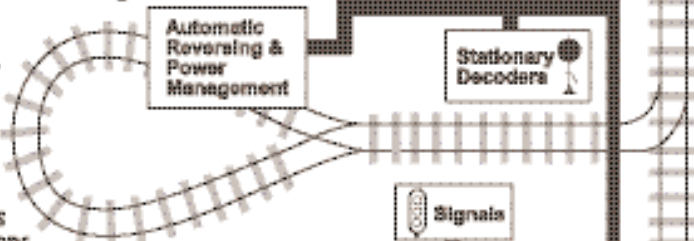

Computer Controls

PDA Throttles & Applications
Computer Interfaces
Programmer

Putting It All Together

The Digitrax Big Book of DCC

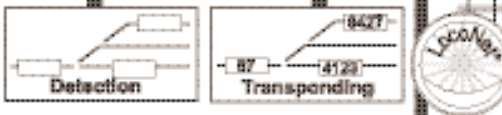

450 Cemetery Street #206
Norcross, GA USA 30071

www.digitrax.com

T 770-441-7992

F 770-441-0759

E sales@digitrax.com

Made in U.S.A.



BDL162



1 23456 78901 2

307-1004-0001