



Digitrax Command Control
Run Your Trains, Not Your Track!

DG583S

G Scale

Mobile Decoder

Fits Large Scale Locomotives
(Screw Terminal for easy installation)

5.0 Amps/10.0 Amps Peak
8 FX³ Functions, 2.0 Amps

Features:

- **Digitrax LocoMotion[®] System**-Your locomotives look like the real thing. The Digitrax LocoMotion System makes them run like the real thing, too!
 - Torque Compensation** for smooth as silk silent operation.
 - 128 Speed Step** operation (14 or 28 steps can also be used).
 - Momentum** with acceleration and deceleration.
 - Normal Direction of Travel** is user selectable.
 - Switching Speed** feature for easier and faster access to yard speeds.
 - 3 Step Speed Tables** set start, mid and max voltage for custom control.
 - 28 Step Speed Tables** with 256 level resolution for precise control.
- **Scaleable Speed Stabilization (Back EMF)** with simple setup & 256 level resolution.
- **SuperSonic** motor drive for silent operation.
- **FX³ Function outputs** for prototypical lighting effects and on/off control:
 - Constant Brightness Lighting** with directional or independent control.
 - Realistic Effects** like Ditch lights, Mars lights, strobes, and many more.
 - FX³ & Standard Function Qualifiers** operate functions based on direction, F0 on or off, direction and F0, and whether loco is moving.
 - Function Remapping** for custom function setup.
 - Master Light Switch** turns off all lights & functions with one keystroke.
 - Advanced Consist Function Controls**
- **Screw Terminal** design makes installation quick and easy.
- **Digitrax 9-Pin Function Plug** for added convenience.
- **Transponder equipped** ready for transponding on your layout.
 - Compatible with digital surround sound systems
- **All Mode Programming with Operations Mode Read Back** reads back CV values right on the mainline with Transponder equipped layouts.
- **Decoder Reset CV** with or without speed table reset.
- **Motor Isolation Protection** prevents damage to your decoder.
- **Basic, Advanced & UniVersal Consisting**
- **2 Digit and 4 Digit Addressing**
- **DCC Compatible**
- **FCC Part 15, Class B RFI compliant**
- **Patent Pending on Super Cool Technology**

Parts List

- | | |
|-----------------------------------|---------------------|
| 1 DG583S Decoder | 1 Instruction sheet |
| 1 Digitrax 9-Pin Function Harness | |

Installation Information

See the Digitrax Decoder Manual for complete decoder test procedures, installation instructions, programming and technical information. Digitrax manuals and instructions are updated periodically. Please visit www.digitrax.com for the latest versions, technical updates and additional locomotive-specific installation instructions.

Installation Instructions

1. Carefully remove the locomotive's shell from the frame. Notice the orientation of the shell to the frame so that you can reinstall correctly.
2. The DG583S uses an easy-to-connect screw terminal for connecting the decoder to the locomotive. Wires from the motor connections and power pickup connections are connected to the decoder according to the following diagram. Simply strip 1/8" of insulation from the end of each wire, insert into the appropriate screw terminal hole and tighten the screw to hold the wire in place. (**Figure 1**). Additional functions can be connected using the 9-pin wiring harness that is supplied with the decoder. See **Figure 2**, (page 6) for instructions for wiring these additional functions.
4. Replace the loco shell. You are now ready to run your locomotive. The DG583S is factory programmed to address 03. You can easily customize the address and other features. See section "Customizing Your Decoder" that follows.

Figure 1. DG583S Decoder Wiring Diagram

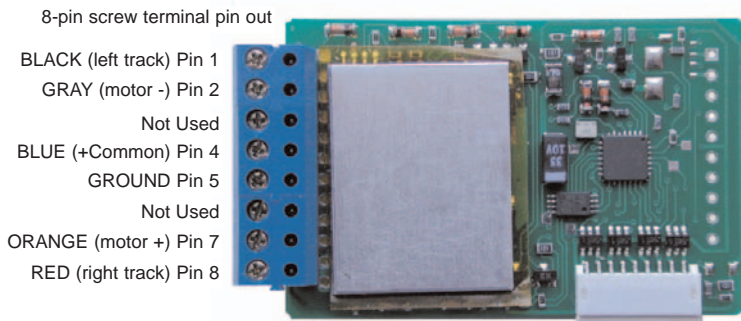



Installation Notes:

1. Function outputs are rated at 2 Amps each. Do not exceed the decoder's 5 Amp total output rating. This total includes the motor current and total of all function output currents.
2. To use a function output with an inductive(coil) type load, see the Digitrax Decoder Manual for more information to avoid damage to the decoder.
3. See the Digitrax Decoder Manual for full details of wiring 12-16V lamps, 1.5V lamps, and LEDs. Lamps that draw more than 80 mA when running require a 22 ohm 1/4 watt resistor in series with the directional light function lead to protect the decoder.

Customizing Your Decoder

Your Digitrax decoder is ready to run and will operate using address 03 with no additional programming. For a more prototypical railroading experience, your decoder can be customized for your specific locomotive and layout requirements by programming some of the Configuration Variables, or CVs, available. See the Digitrax Decoder Manual or the Digitrax website for complete information on how to use CVs.

Changing the Decoder Address

The first CV most people change is the decoder address. This allows you to independently control each loco with a unique address. Digitrax decoders are shipped with CV01 (AD2), the two digit address, set to 03. Following is a brief description of how to change the decoder address with a Digitrax DT series throttle. See your Starter Set Manual for complete programming instructions.

1. Place the loco on the programming track. Go into Program Mode on your system. On DT400 press **PROG**. On DT300, DT100 & DT200 press **RUN/STOP & FN/F0**.
2. Choose AD2 for 2 digit addressing or AD4 for 4 digit addressing (DT300 & DT400). (Ad for DT100 & DT200, see set manual for 4 digit instructions).
3. Choose the address you want to set up for the decoder.
4. Complete address programming. On DT400 press **ENTER**. On DT300, DT100 & DT200 press **SEL**.

Note: CV29 must also be programmed to enable 4 digit addressing, this is done automatically by the DT300 & DT400 but not on earlier throttles.



Digitrax LocoMotion® System

Your locomotives look like the real thing, now you can make them run like the real thing, too. Digitrax decoders incorporate torque compensation for smooth as silk operation. You can also program CVs that control momentum, 3 step and 128 step speed tables, switching speed, normal direction of travel, scaleable speed stabilization and more to take full advantage of the Digitrax LocoMotion™ System.

Momentum-CV03 & CV04

Momentum is part of the LocoMotion™ System. Acceleration is controlled by CV03 and deceleration by CV04. Both come from the factory set to 000/x00. A range of 000/x00/ to 031/x1F is available for both accel and decel. We recommend that you try CV03:003/x03 and CV04:000/x00 as a starting point for experimenting with momentum.

Speed Tables-How the Loco Responds to the Throttle

With Digitrax LocoMotion™, there are two types of speed tables: 3 Step Tables and High Resolution 28 Step Tables. Please see your Decoder Manual for a discussion of the 28 Step Tables. The 3 Step Tables are set up by programming 3 CVs: Start Voltage (CV02), Mid point Voltage (CV06) and Max Voltage (CV05). These values are set at 000/x00 at the factory. All have a range of values from 000/x00 to 255/xFF. We recommend the following CV values as a starting point for experimenting with speed tables.

Loco Type	V Start CV02	V Mid CV06	V Max CV05
Switcher Concentrated low speed. Limited top speed	002/x02	038/x26	064/x50
Road Switcher Prototypical top speed w/evenly distributed curve from 0 to top speed	002/x02	048/x30	098/x62
Mainline Loco Quick increase to cruising speed then levels off to prototypical top speed.	002/x02	128/x80	154/x9A



2443 Transmitter RD
Panama City, FL 32404
www.digitrax.com

T 850-872-9890
F 850-872-9557
E sales@digitrax.com

Other LocoMotion[™] Features: Switching Speed, Normal Direction of Travel & Scaleable Speed Stabilization (Back EMF) Features

Switching speed is controlled by CV54. The factory setting is 000/x00 for OFF. To turn on the switching speed feature, program CV54 to a value of 001/x01. When this feature is on, use F6 to activate and deactivate switching speed. When switching speed is ON and F6 is ON, the switching speed feature is on. With the feature on the throttle's target speed is effectively reduced by about 50% and the effects of accel and decel programmed into the decoder are reduced by 1/4. This is useful for yard switching operations.

Normal Direction of Travel is controlled by CV29. See your decoder manual for additional information on the settings for CV29.

The intensity, or droop, of **Scaleable Speed Stabilization (Back EMF)** is controlled by CV57. The factory setting for this feature is 006/x06 which is suitable for most locos. You can adjust this value in the range of 000/x00 for OFF to 015/x0F for the maximum effect. Consult your Digitrax Decoder Manual for info about CVs 55 & 56 and their effects on scaleable speed stabilization.

SuperSonic[™] Silent Operation and Torque Compensation

The factory settings in the decoder provide silent, smooth operation of your locomotive under most conditions. For more information about these settings, please see the Digitrax Decoder Manual or our web site.

Function Outputs on the DG583S

The DG583S has eight function outputs available using the 9-pin connector located on the underside of the decoder (*Figure 2*). Connections for F0F and F0R, as well as functions F1, F2, F3, F4, F5 and F6 are available using the 9 pin function harness supplied with the decoder. These functions can be used by soldering the wires as indicated in the wiring diagram (*Figure 2*) to additional lights (or other functions) you wish to control.

All 8 function outputs can be programmed as Digitrax FX³ lighting effects or as standard on/off functions.

All function outputs can be qualified based on:

1. Forward or Reverse direction of travel, or
2. Whether F0 is on or off, or
3. Both direction of travel and whether F0 is on or off, or
4. Whether the locomotive is stopped or moving.

Master Light Switch

Each of the 8 function outputs can be programmed to turn on and off with the

Figure 2. DG583S Decoder Function Outputs

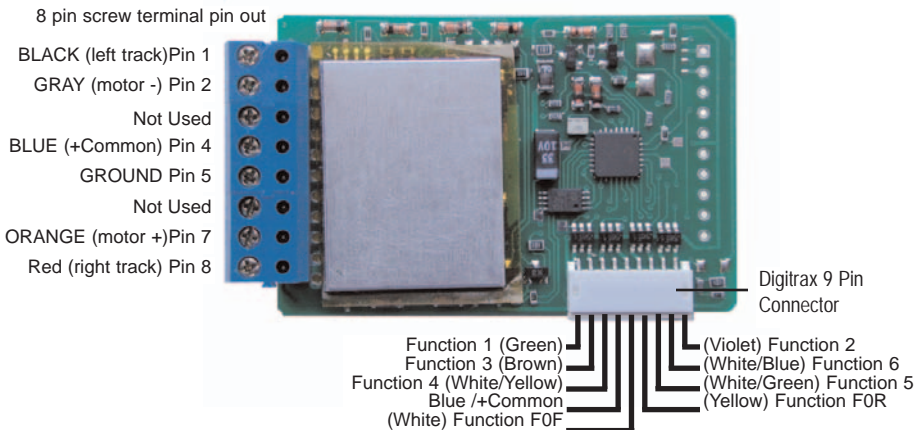

F0 ON/OFF key on your throttle, creating a Master Light Switch. The CV values for creating this effect are listed in the Digitrax Decoder Manual.



Function Remapping

Function remapping lets you program any function output on your decoder to be controlled by any function key on your throttle. Please consult the Digitrax Decoder Manual or web site for information on function remapping.

Digitrax Transponding CV61

Digitrax Transponding is controlled by CV61. The initial factory set value is 000/x00 (OFF). To turn on transponding, program CV61 to a value of 002/x02. This allows you to use Digitrax transponding to keep track of your rolling stock. When transponding is enabled, the front light of the locomotive will flicker slightly to indicate that a transponding signal is being communicated.

Decoder Reset CV08

Decoder reset lets you restore all CV values to their initial factory settings. To reset all CV values, program CV08 to a value of 008/x08. To reset all CV values EXCEPT for the values entered in your 28 speed step tables, program CV08 to a value of 009/x09.

Warranty & Repair

All warranties on Digitrax products are limited to refund of purchase price, repair or replacement at Digitrax's sole discretion. Except as expressly stated in the full warranty statement, there are no warranties, express or implied, including but not limited to any warranties of merchantability or fitness for a particular purpose. For complete warranty details see www.digitrax.com.

Damaged decoders should be returned directly to Digitrax for repair.

Digitrax, Inc. is not responsible for unintentional errors or omissions in this document.

DG583S can be used with Lionel AC Motors. too!
See www.digitrax.com or the Digitrax Big Book of
DCC for wiring instructions.



DG583S
G Scale Decoder

Go Beyond DCC With Digitrax

Complete Train Control

Main Station

Starter Sets
LocoNet®
Power Supplies



Your Digitrax LocoNet® Starter Set is just the beginning of an exciting trip! Pick the one that's right for you!



LocoNet®
The Digitrax Difference

Locomotive Shops

Mobile Decoders
Function Decoders
SoundFX™ Decoders



More Fun For Everyone

Add More Boosters, Advanced & Simple Throttles, Power Supplies, Universal Panels, IR and/or Radio for more trains and operators.

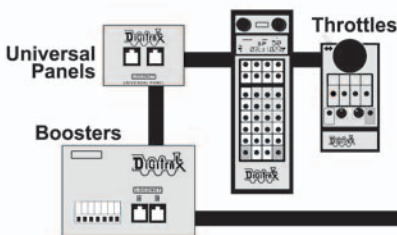

Maintenance Of Way

Make your layout more fun & simpler to operate!

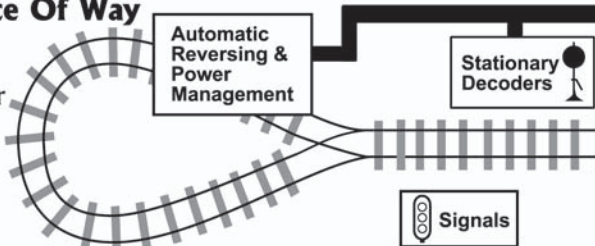

Computer Controls

Computer Interface Programmer

It All Adds Up To Complete Train Control

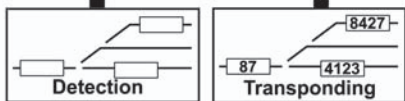

2443 Transmitter Road
Panama City, FL 32404
www.digitrax.com
T 850-872-9890
F 850-872-9557
E sales@digitrax.com

Made in U.S.A.



DG583S



6 52667 07005 8

1000/12/08

307-5002-0000